

**Woak**

**22**

A melting pot DNA where skills originate from crossed cultures and combine with the woodworking tradition of the land where the raw material comes from. Woak symbolises the strength of a company and the desire to open up to the new with an almost nomad vocation to travel and absorb knowledge from all over the world and then mix it with the original heritage of craftsmanship carpentry.

Instead of products, we create "pieces", crafted with great care for the users as well the environment. We are passionate about working with the warmth of solid wood, especially oak and walnut, and attach great importance to sustainable raw materials.

# Woak

BRIONI designed by Zoran Jedrejčić .  
An apparently "simple" object like the chair becomes the center of meticulous design study aimed at obtaining a mix of lightness, ergonomic, iconic shape, resistance and versatility. The key factors lie not only in design but also in the search for right materials and connections.

# BRIONI

# 22



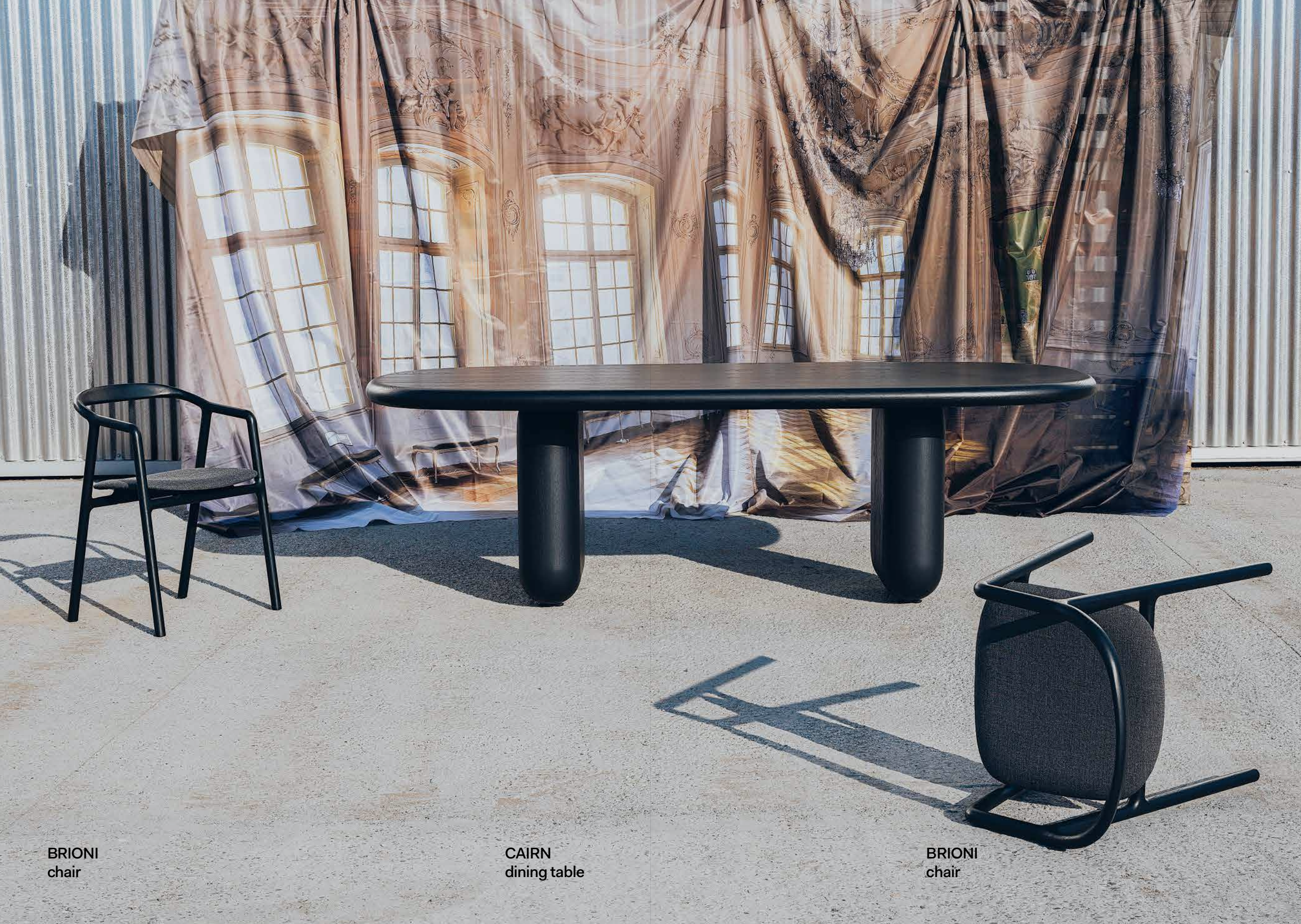

BRIONI  
chair

CAIRN  
dining table

BRIONI  
chair



BRIONI  
chair



**BRIONI  
chair**

Design: Zoran Jedrejčić  
Material: Walnut, oak or painted wood, fabric, leather.  
Surface treatment: Lacquer or oil

**Dimensions**

W		D		H
53 cm	x	50 cm	x	75 cm



**BRIONI  
stool**

Design: Zoran Jedrejčić  
 Material: Walnut, oak or painted wood, fabric, leather.  
 Surface treatment: Lacquer or oil

**Dimensions**

W		D		H
50 cm	x	47 cm	x	60 cm



**BRIONI  
bar stool high  
BRIONI  
bar stool low**

Design: Zoran Jedrejčić  
 Material: Walnut, oak or painted wood, fabric, leather.  
 Surface treatment: Lacquer or oil

**Dimensions**

W		D		H
50 cm	x	49 cm	x	88 cm
50 cm	x	48 cm	x	78 cm

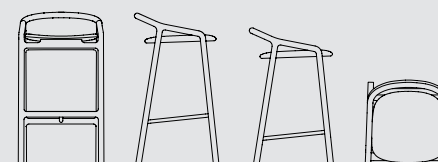



BRIONI  
bar stool  
high

A melting pot DNA where skills originate from crossed cultures and combine with the woodworking tradition of the land where the raw material comes from. Woak symbolises the strength of a newly independent country and the desire to open up to the new with an almost nomad vocation to travel and absorb knowledge from all over the world and then mix it with the original heritage of craftsmanship carpentry.

Instead of products, we create "pieces", crafted with great care for the users as well the environment. We are passionate about working with the warmth of solid wood, especially oak and walnut, and attach great importance to sustainable raw materials.

Designed by Zoran Jedrejčić.  
Bled is a traditional Chair in the best sense of the word. With its subtle lines and compact dimensions Bled Chair is exceptionally light, both physically and visually. This simple and clean design would not compromise the harmony of any interior.

Bled Chair with its upholstered seat and pronounced armrest is suitable for frequent use in public spaces, such as restaurants, bars and hotels, but it is also perfect for private interiors.

# Woak

# BLED

# 22





BLED  
chair



**BLED  
chair**



**BLED  
chair**

Design: Zoran Jedrejčić  
Material: Walnut, oak or painted wood, Fabric, Leather  
Surface treatment: Lacquer or oil

**Dimensions**

W		D		H
54 cm	x	53 cm	x	78 cm



BLED  
chair

A melting pot DNA where skills originate from crossed cultures and combine with the woodworking tradition of the land where the raw material comes from. Woak symbolises the strength of a company and the desire to open up to the new with an almost nomad vocation to travel and absorb knowledge from all over the world and then mix it with the original heritage of craftsmanship carpentry.

Instead of products, we create "pieces", crafted with great care for the users as well the environment. We are passionate about working with the warmth of solid wood, especially oak and walnut, and attach great importance to sustainable raw materials.

Designed by Ado Avdagić.

The main idea behind Bud was to develop a working home desk that would be versatile as much as possible utilizing natural materials while preserving warmth of home, well engineered, sustainable and finished with handcrafted know-how. The desk is made of solid wood oak and walnut as a bright and dark version, brass hinges on flaps and Kvadrat 100% wool in a range of selected colours which provide acoustic features.

# Woak

# BUD

# 22

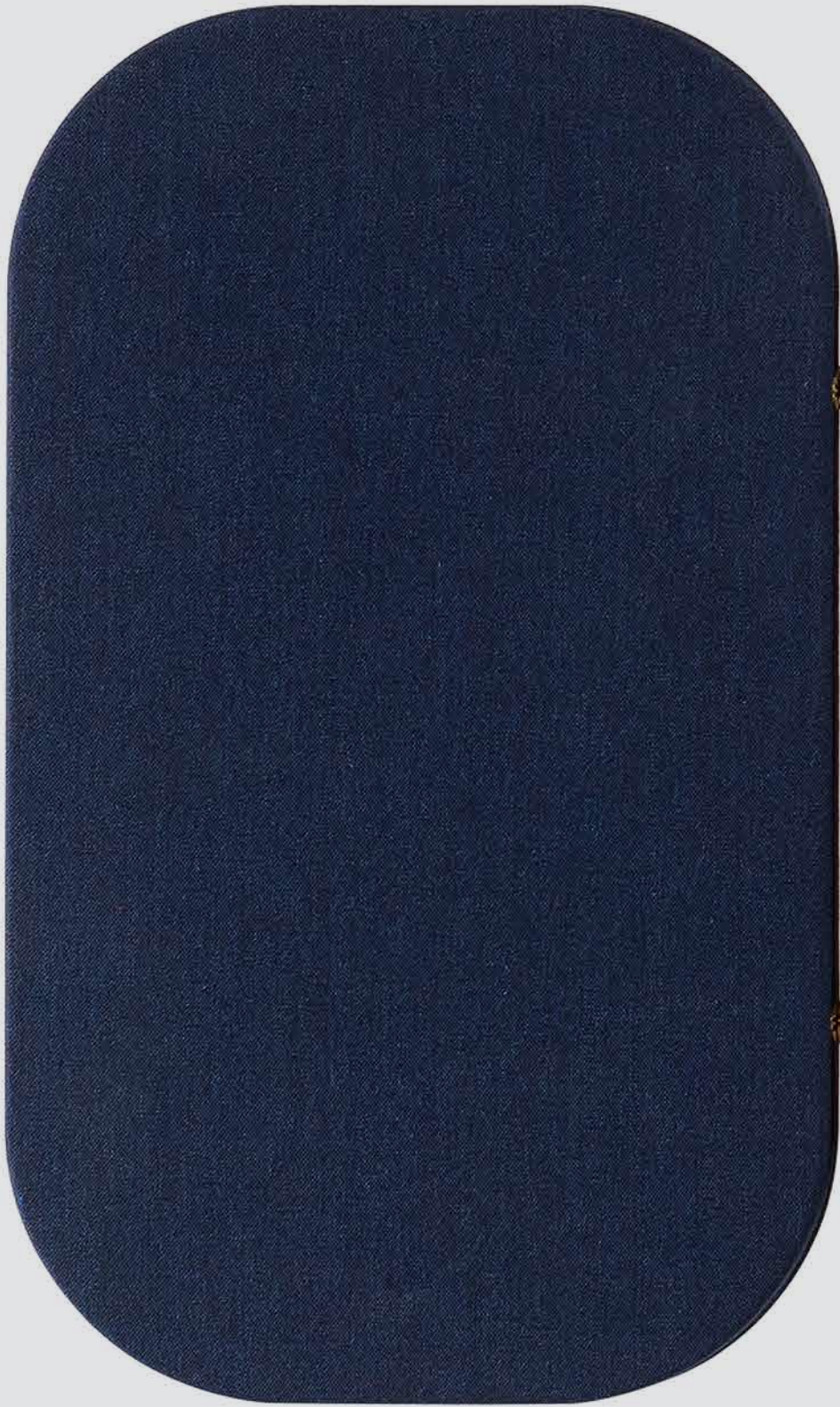

BUD  
working desk



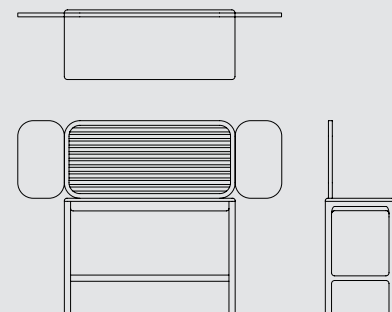

**BUD  
working desk**

Design: Ado Avdagić  
Material: Walnut or oak  
Fabric  
Surface treatment: Lacquer or oil

**Dimensions**

W		D		H
110 cm	x	45 cm	x	75/125 cm



BUD  
working desk

A melting pot DNA where skills originate from crossed cultures and combine with the woodworking tradition of the land where the raw material comes from. Woak symbolises the strength of a company and the desire to open up to the new with an almost nomad vocation to travel and absorb knowledge from all over the world and then mix it with the original heritage of craftsmanship carpentry.

Instead of products, we create "pieces", crafted with great care for the users as well the environment. We are passionate about working with the warmth of solid wood, especially oak and walnut, and attach great importance to sustainable raw materials.

# Woak

Designed by Matteo Zorzenoni.  
From the idea of the unstable equilibrium of the Cairn Stones of the Zen world, Cairn is born, a table composed of two full-bodied legs and a generous top made of solid wood. All surfaces are soft and smooth, just like pebbles smoothed by the flow of water.

# CAIRN

# 22





BRIONI  
chair

CAIRN  
dining table



CAIRN  
dining table

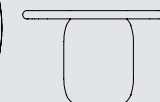
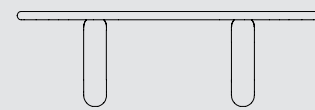

**CAIRN**  
dining table

**Dimensions**

Design: Matteo Zorzenoni  
Material: Walnut or oak  
Surface treatment: Lacquer or oil

W		D		H
200 cm	x	105 cm	x	75 cm
240 cm	x	120 cm	x	75 cm
300 cm	x	120 cm	x	75 cm



CAIRN  
dining table





A meltin pot DNA where skills originate from crossed cultures and combine with the woodworking tradition of the land where the raw material comes from. Woak symbolises the strength of a company and the desire to open up to the new with an almost nomad vocation to travel and absorb knowledge from all over the world and then mix it with the original heritage of craftsmanship carpentry.

Instead of products, we create "pieces", crafted with great care for the users as well the environment. We are passionate about working with the warmth of solid wood, especially oak and walnut, and attach great importance to sustainable raw materials.

# Woak

CRICKET designed by Matteo Zorzenoni. Organic and soft shapes outline Cricket, a coat hanger with integrated wall mirror made of solid wood. Two elegant wooden tubes curved at the ends determine its shape, making it look like a macro ant.

# CRICKET

# 22



BRIONI  
chair

CAIRN  
dining  
table

CRICKET  
hanger with  
mirror

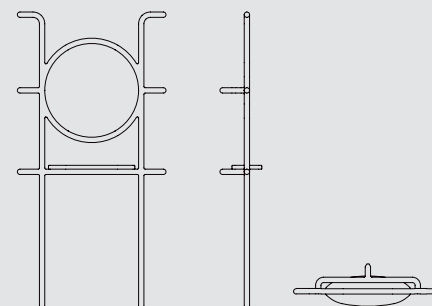
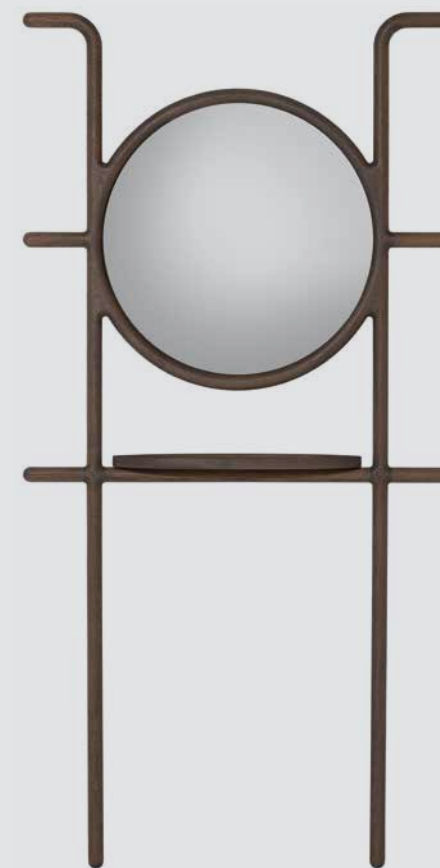

**CRICKET  
hanger with  
mirror**

Design: Matteo Zorzenoni  
Material: Walnut or oak  
Surface treatment: Lacquer or oil

**Dimensions**

W		D		H
98 cm	x	27,5 cm	x	195 cm
103 cm	x	27,5 cm	x	195 cm



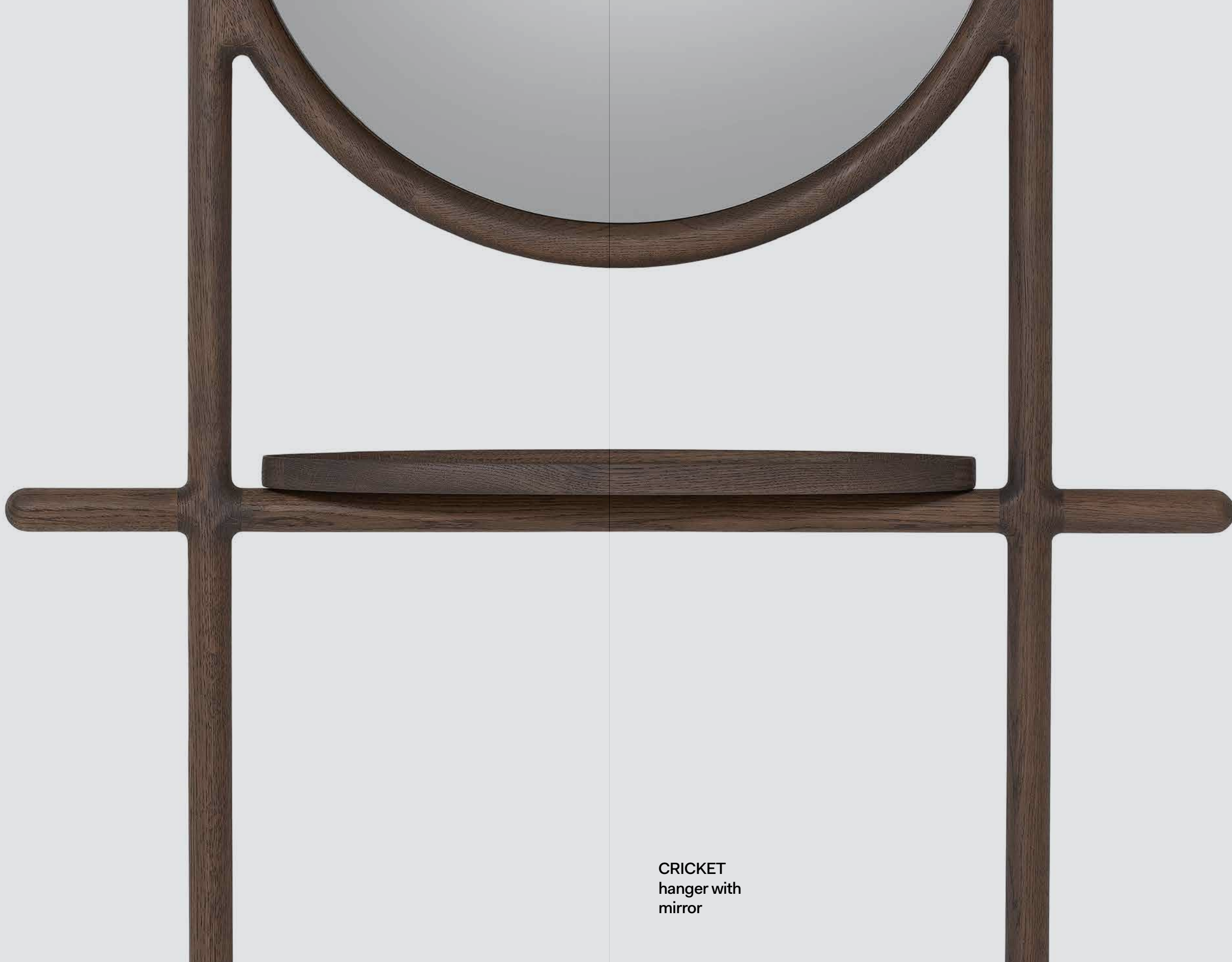

CRICKET  
hanger with  
mirror



CRICKET  
hanger with  
mirror



A meltin pot DNA where skills originate from crossed cultures and combine with the woodworking tradition of the land where the raw material comes from. Woak symbolises the strength of a company and the desire to open up to the new with an almost nomad vocation to travel and absorb knowledge from all over the world and then mix it with the original heritage of craftsmanship carpentry.

Instead of products, we create "pieces", crafted with great care for the users as well the environment. We are passionate about working with the warmth of solid wood, especially oak and walnut, and attach great importance to sustainable raw materials.

# Woak

Designed by Constance Guisset.  
Diorama is a collection of tables to dream yourself as a curator. A crystal-clear dialog takes place between oak and glass to form a precious case with a concealed technicality. Under the guise of a cabinet of curiosities, the table invites to display treasures. An easy system of opening makes our little world close at hand.

# DIORAMA

# 22

HAKU  
console with mirror



WHERRY  
Armchair



DIORAMA  
coffee table

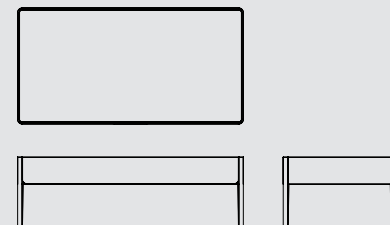
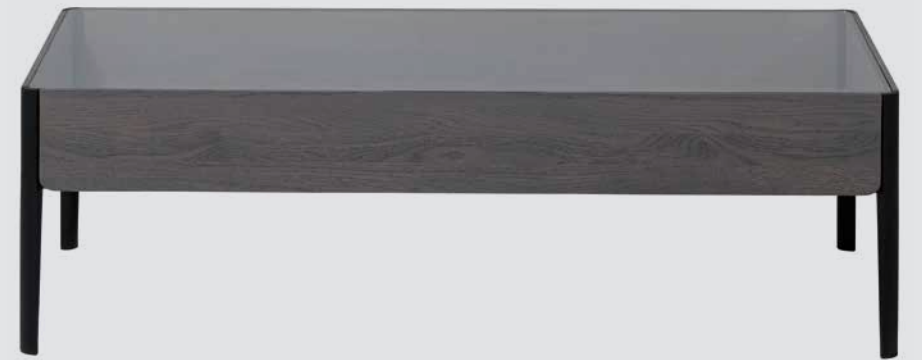

**DIORAMA  
coffee table**

Design: Constance Guisset  
Material: Walnut , Oak, Glass  
Surface treatment: Oil

**Dimensions**

W		D		H
60 cm	x	40 cm	x	36 cm
70 cm	x	50 cm	x	36 cm
120 cm	x	60 cm	x	36 cm

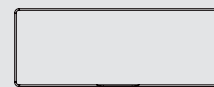

**DIORAMA  
console**

Design: Constance Guisset  
Material: Walnut , Oak, Glass  
Surface treatment: Oil

**Dimensions**

W		D		H
120 cm	x	45 cm	x	80 cm



DIORAMA  
coffee table





A melting pot DNA where skills originate from crossed cultures and combine with the woodworking tradition of the land where the raw material comes from. Woak symbolises the strength of a company and the desire to open up to the new with an almost nomad vocation to travel and absorb knowledge from all over the world and then mix it with the original heritage of craftsmanship carpentry.

Instead of products, we create "pieces", crafted with great care for the users as well the environment. We are passionate about working with the warmth of solid wood, especially oak and walnut, and attach great importance to sustainable raw materials.

**DUOMO Chair designed by Andrea Steidl**  
Duomo is a challenge of woodworking construction with such a complex exterior. It is not only a bold statement furniture piece, but also a tribute and display of excellent craftsmanship. While the chairs' straight lines and soft backrest come together in a play of contrast between massive wood and empty spaces, as you get closer you can admire the rich details of its intricate wood working.

Its vertical and straight aesthetic make it close to the vertical and detailed appearance of European Duomo, as the Milanese one, that with its impressive façade and bold presence has become an icon of the city it represents.

# Woak

# DUOMO

# 22



DUOMO  
chair

DUOMO  
chair





DUOMO  
chair

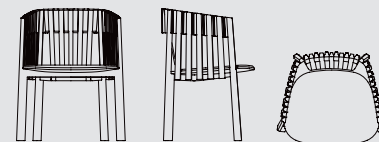

**DUOMO  
chair**

Design: Andrea Steidl  
Material: Walnut, oak or  
painted wood  
Fabric, leather  
Surface treatment: Lacquer or oil

**Dimensions**

W		D		H
62 cm	x	53 cm	x	75 cm



DUOMO  
chair



A melting pot DNA where skills originate from crossed cultures and combine with the woodworking tradition of the land where the raw material comes from. Woak symbolises the strength of a company and the desire to open up to the new with an almost nomad vocation to travel and absorb knowledge from all over the world and then mix it with the original heritage of craftsmanship carpentry.

Instead of products, we create "pieces", crafted with great care for the users as well the environment. We are passionate about working with the warmth of solid wood, especially oak and walnut, and attach great importance to sustainable raw materials.

# Woak

Designed by Christophe de la Fontaine  
HAKU is a severe yet articulate set of wooden cabinets, from wall-mounted to freestanding or even equipped with a mirror. Breaking the ever-present orthogonality typically found throughout ordinary box furniture, HAKU explores the principle of axial repetition. Taking advantage of its spatial perception while favouring the act of a non linear interaction.

# HAKU

# 22



WHERRY  
Armchair

DIORAMA  
coffee table

HAKU  
console with mirror

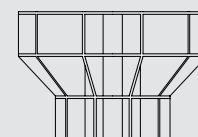
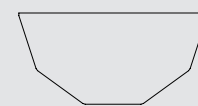

## HAKU console

Design: Christophe De  
La Fontaine  
Material: Walnut or oak  
Surface treatment: Oil

### Dimensions

W		D		H
107 cm	x	52 cm	x	73.5 cm

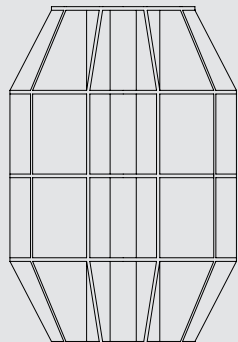
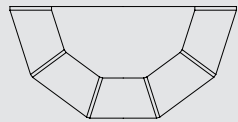

**HAKU  
bookshelf**

Design: Christophe De La Fontaine  
 Material: Walnut or oak  
 Surface treatment: Oil

**Dimensions**

W		D		H
95 cm	x	46 cm	x	139,5 cm

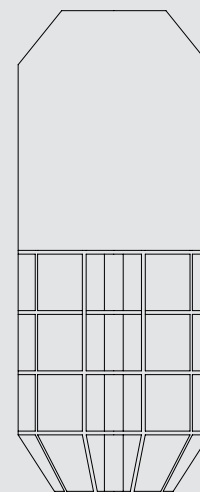
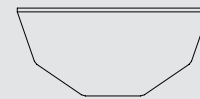

**HAKU  
console  
with mirror**

Design: Christophe De La Fontaine  
 Material: Walnut or oak  
 Mirror in Clear, Gray or Bronze  
 Surface treatment: Oil

**Dimensions**

W		D		H
71,5 cm	x	35 cm	x	193 cm

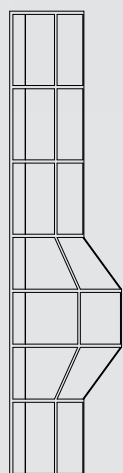
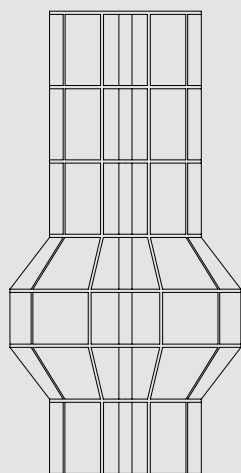
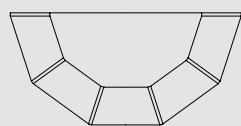

**HAKU**  
self standing  
storage

Design: Christophe De La Fontaine  
Material: Walnut or oak  
Surface treatment: Oil

**Dimensions**

W		D		H
107 cm	x	52 cm	x	216 cm





A meltin pot DNA where skills originate from crossed cultures and combine with the woodworking tradition of the land where the raw material comes from. Woak symbolises the strength of a company and the desire to open up to the new with an almost nomad vocation to travel and absorb knowledge from all over the world and then mix it with the original heritage of craftsmanship carpentry.

Instead of products, we create "pieces", crafted with great care for the users as well the environment. We are passionate about working with the warmth of solid wood, especially oak and walnut, and attach great importance to sustainable raw materials.

Designed by Woak.

The soul of the collection is the fluidity of the shapes that fills each joint or intersection as if the object did not derive from the union of the components but was a single molded piece, with geometries so fluid as to seem like a printed piece. The purity of the material evokes a tactile sensation, tempting to touch those surfaces perfectly smooth to the touch but visually rich in natural veins. The organic forms call to mind the classics of Northern European cabinet-making with a reference to some iconic elements of design from the 1950s but remade in a contemporary perspective. Like the rounded corners that give a bourgeois aura and the legs that suspend the elements, putting spaces to fill, synonymous with visual comfort, in the center of the scene. Infact the collection mainly consists of cabinets and tables or in any case furniture with shelves and the imagination goes to the reassuring atmospheres of the houses of those years, however revised with a minimalist view.

# Woak

# MALIN

# 22



MALIN  
shelf  
system



**MALIN  
shelf  
system**

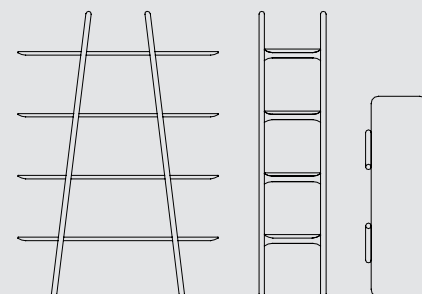

**MALIN  
shelf  
system**

**Dimensions**

Design: Woak  
 Material: Walnut or oak  
 Marble, Terrazzo  
 Surface treatment: Oil

W		D		H
120 cm	x	40 cm	x	170 cm
120 cm	x	40 cm	x	134 cm





MALIN  
working  
desk

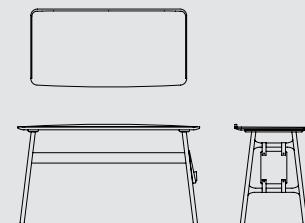

**MALIN  
working  
desk**

Design: Woak  
Material: Walnut or oak  
Leather  
Surface treatment: Lacquer or oil

**Dimensions**

W		D		H
120 cm	x	60 cm	x	75 cm
140 cm	x	60 cm	x	75 cm

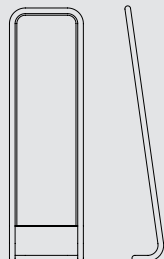

**MALIN  
mirror**

Design: Woak  
 Material: Walnut or oak  
 Surface treatment: Oil

**Dimensions**

W		D		H
42 cm	x	25.5 cm	x	165 cm

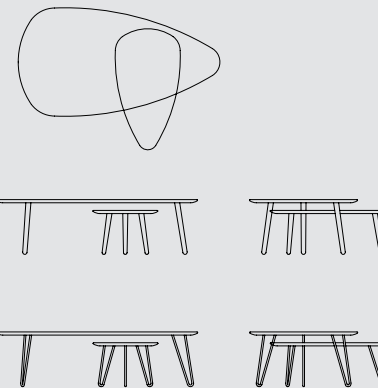

**MALIN  
coffee  
tables**

Design: Woak  
 Material: Walnut or oak  
 Surface treatment: Oil  
 Option: Metal legs  
 Wooden legs

**Dimensions**

W		D		H
140 cm	x	75 cm	x	38 cm
120 cm	x	64.5 cm	x	38 cm
84 cm	x	45 cm	x	30.5 cm



**MALIN  
tv unit**

Design: Woak  
 Material: Walnut or oak  
 Surface treatment: Oil  
 Option: Metal legs  
 Wooden legs

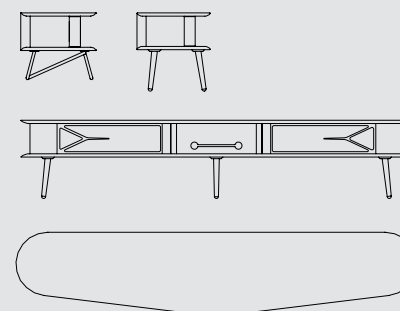

**Dimensions**

W		D		H
180 cm	x	45 cm	x	40/48 cm
200 cm	x	50 cm	x	40/48 cm
220 cm	x	50 cm	x	40/48 cm
240 cm	x	50 cm	x	40/48 cm



**MALIN**  
side table  
with glass top

Design: Woak  
Material: Walnut or oak  
Surface treatment: Oil

**Dimensions**

W		D		H
42 cm	x	42 cm	x	45 cm



**MALIN**  
side table  
round

Design: Woak  
Material: Walnut or oak  
Copper  
Surface treatment: Oil

**Dimensions**

W		D		H
42.5 cm	x	42.5 cm	x	50 cm





MALIN  
side table  
round



MALIN  
side table  
square



MALIN  
side table  
square

Design: Woak  
Material: Walnut or oak  
Marble  
Surface treatment: Oil

Dimensions

W		D		H
40 cm	x	40 cm	x	50 cm



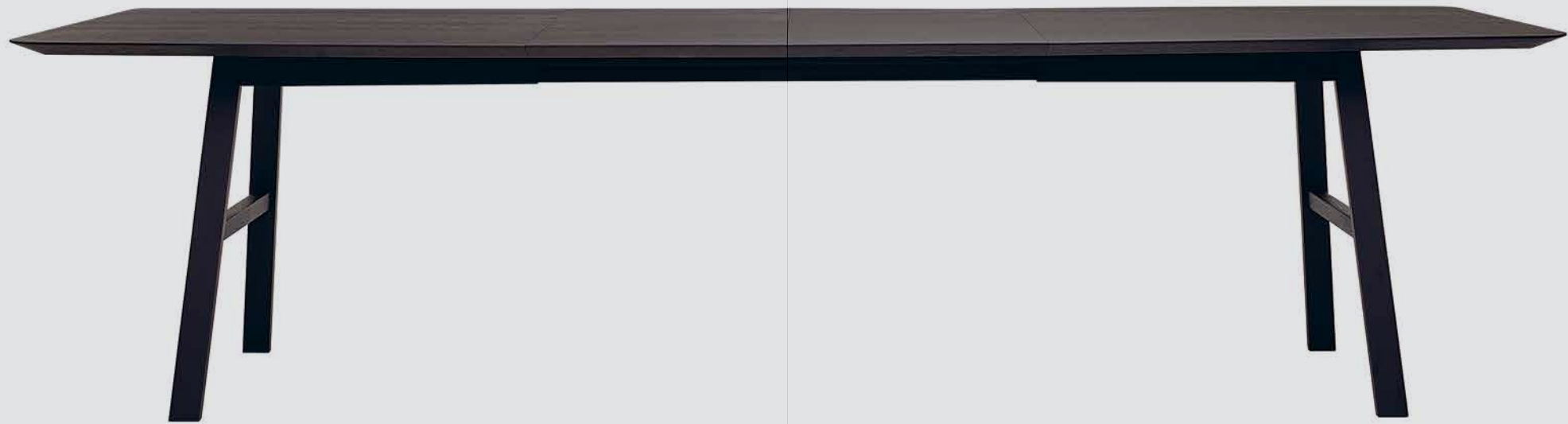

**MALIN  
dining table**

Design: Salih Teskeredžić  
 Material: Walnut or oak  
 Surface treatment: Lacquer or oil

**Dimensions**

W		D		H
160 cm	x	90/100 cm	x	75 cm
180 cm	x	90/100 cm	x	75 cm
Option: Extension Leaf 50 cm (1 or 2)				
200 cm	x	90 cm	x	75 cm
Option: Extension Leaf 50 cm (1 or 2)				
200 cm	x	100 cm	x	75 cm
220 cm	x	90/100 cm	x	75 cm
240 cm	x	90/100 cm	x	75 cm
300 cm	x	100 cm	x	75 cm

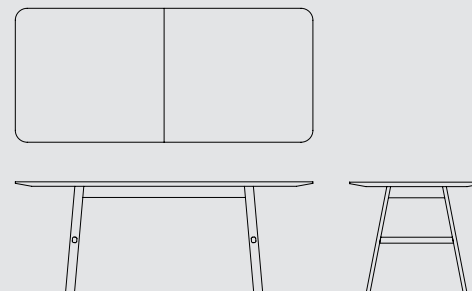



MALIN  
dining table





A melting pot DNA where skills originate from crossed cultures and combine with the woodworking tradition of the land where the raw material comes from. Woak symbolises the strength of a company and the desire to open up to the new with an almost nomad vocation to travel and absorb knowledge from all over the world and then mix it with the original heritage of craftsmanship carpentry.

Instead of products, we create "pieces", crafted with great care for the users as well the environment. We are passionate about working with the warmth of solid wood, especially oak and walnut, and attach great importance to sustainable raw materials.

MARSHALL designed by Zoran Jedrejčić .  
At the table, on the chair we socialise, drink, eat, tell over events and become more familiar with each other. Around this practically sacred objects, whole families and statesmen gather. Each of us in our memories carries our own table, chair, bench. It was while these memories were being played, that the Marshall Collection came about. With the Marshall Collection we carefully put in the center these memories and simple joy of life, by underlining everyday needs to touch, observe, listen, relax, enjoy, eat... The typology of chosen pieces and dialectic of the forms are simple, masculine but fluid, always in balance between thin wooden structure opposing to other natural materials carefully selected to complete each piece of the Marshall Collection such as the untreated leather, the pure marble or the cast glass with its changing colours. Those combination of hot and cold materials leads to a perfect balance not only in sight but also in touch.

# Woak

# MARSHALL

# 22



WING  
coffee table

MARSHALL  
lounge chair

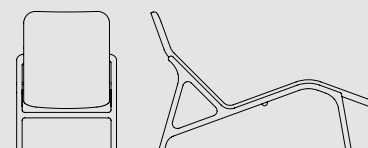
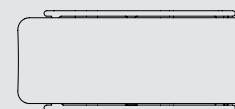

**MARSHALL  
lounge  
chair**

Design: Zoran Jedrejčić  
Material: Walnut or oak  
Leather  
Surface treatment: Lacquer or oil

**Dimensions**

W		D		H
63 cm	x	147 cm	x	91 cm

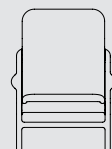
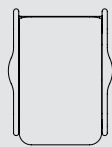

**MARSHALL  
armchair  
high**

Design: Zoran Jedrejčić  
 Material: Walnut, oak or painted wood  
 Leather  
 Surface treatment: Lacquer or oil

**Dimensions**

W		D		H
63 cm	x	93 cm	x	96 cm

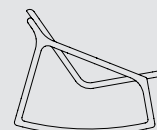
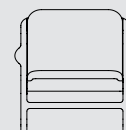
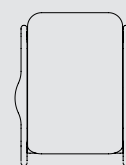

**MARSHALL  
rocking  
armchair**

Design: Zoran Jedrejčić  
 Material: Walnut, oak or painted wood  
 Leather  
 Surface treatment: Lacquer or oil

**Dimensions**

W		D		H
69 cm	x	90 cm	x	73 cm



MARSHALL  
armchair low

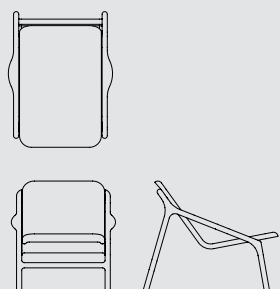

**MARSHALL  
armchair  
low**

Design: Zoran Jedrejčić  
 Material: Walnut, oak or painted wood  
 Leather  
 Surface treatment: Lacquer or oil

**Dimensions**

W		D		H
69 cm	x	93 cm	x	73 cm



**MARSHALL  
tabouret**

Design: Zoran Jedrejčić  
 Material: Walnut or oak  
 Leather  
 Surface treatment: Lacquer or oil

**Dimensions**

W		D		H
55 cm	x	41.5 cm	x	40 cm



**MARSHALL**  
chair

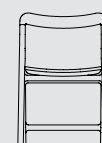
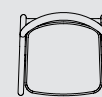

**MARSHALL**  
chair

Design: Zoran Jedrejčić  
Material: Walnut, oak or painted wood  
Leather  
Surface treatment: Lacquer or oil

**Dimensions**

W		D		H
53 cm	x	48 cm	x	78 cm



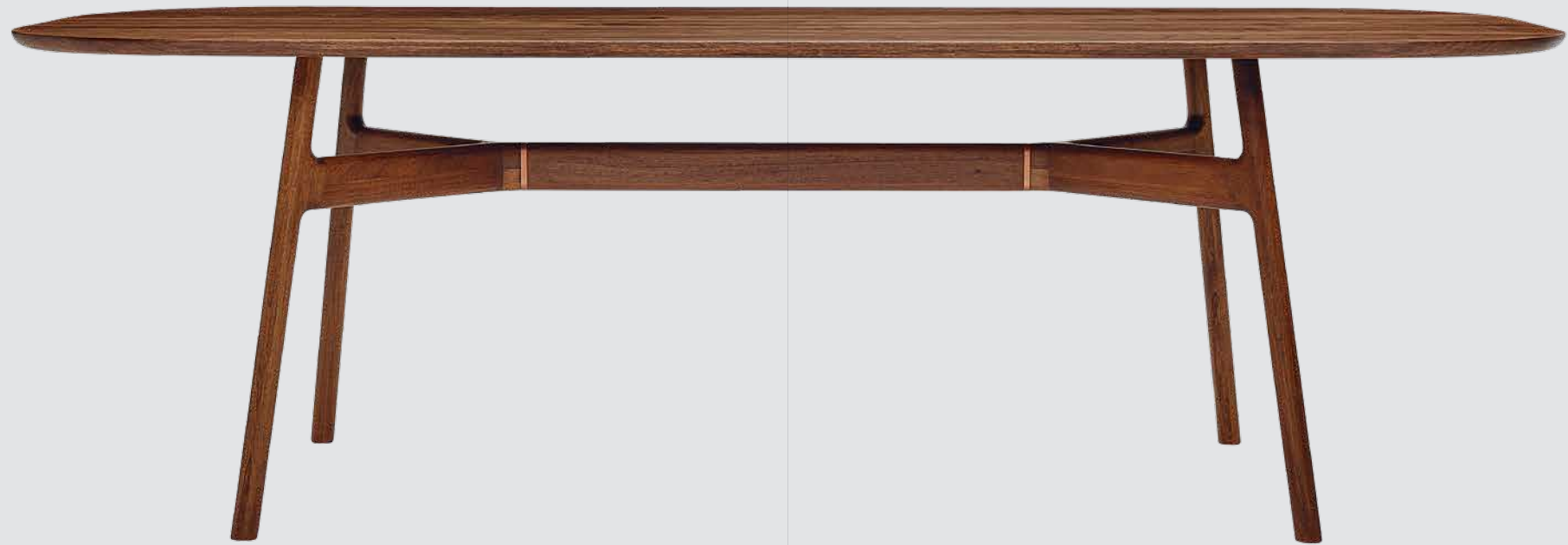

**MARSHALL**  
dining table

Design: Zoran Jedrejčić  
Material: Walnut or oak  
Surface treatment: Lacquer or oil

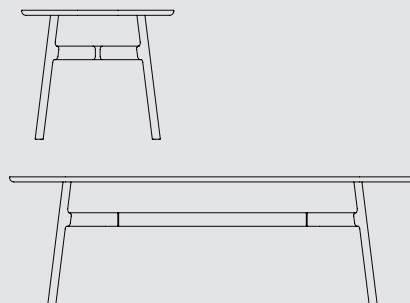

**Dimensions**

W		D		H
180 cm	x	90 cm	x	75 cm
200 cm	x	90 cm	x	75 cm
220 cm	x	90 cm	x	75 cm
240 cm	x	90 cm	x	75 cm
300 cm	x	90 cm	x	75 cm

W		D		H
180 cm	x	100 cm	x	75 cm
200 cm	x	100 cm	x	75 cm
220 cm	x	100 cm	x	75 cm
240 cm	x	100 cm	x	75 cm
300 cm	x	100 cm	x	75 cm



MARSHALL  
dining table



MARSHALL  
coffee table



**MARSHALL  
coffee  
table**

Design: Zoran Jedrejčić  
Material: Walnut or oak  
Marble  
Leather  
Surface treatment: Lacquer or oil

**Dimensions**

W		D		H
44 cm	x	44 cm	x	42.5 cm



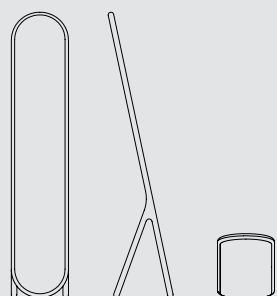

**MARSHALL  
self standing  
mirror**

Design: Zoran Jedrejčić  
Material: Walnut or oak  
Surface treatment: Lacquer or oil

**Dimensions**

W		D		H
33 cm	x	38 cm	x	166 cm

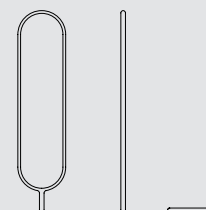

**MARSHALL  
wall mirror**

Design: Zoran Jedrejčić  
Material: Walnut or oak  
Surface treatment: Lacquer or oil

**Dimensions**

W		D		H
33 cm	x	7 cm	x	140 cm
33 cm	x	7 cm	x	168 cm



**MARSHALL  
ladders**

Design: Zoran Jedrejčić  
 Material: Walnut or oak  
 Bottom Shelf: Marble or terazzo  
 Surface treatment: Lacquer or oil

**Dimensions**

W		D		H
40 cm	x	40 cm	x	166 cm

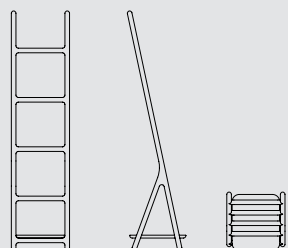



**MARSHALL  
coat rail**

Design: Zoran Jedrejčić  
 Material: Walnut or oak  
 Bottom shelf: Marble or terazzo  
 Surface treatment: Lacquer or oil

**Dimensions**

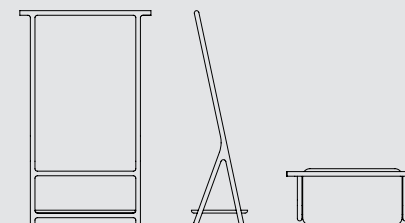
W		D		H
91 cm	x	39 cm	x	150 cm





MARSHALL  
coat rail



A melting pot DNA where skills originate from crossed cultures and combine with the woodworking tradition of the land where the raw material comes from. Woak symbolises the strength of a company and the desire to open up to the new with an almost nomad vocation to travel and absorb knowledge from all over the world and then mix it with the original heritage of craftsmanship carpentry.

Instead of products, we create "pieces", crafted with great care for the users as well the environment. We are passionate about working with the warmth of solid wood, especially oak and walnut, and attach great importance to sustainable raw materials.

Designed by Simon Morasi Piperčič.  
Most of the seating benches currently on the market are uncomfortable because their seating surface is flat. Therefore, we have decided to add a concave slot through the whole length of the seating surface, to make it more comfortable and allow for longer seating time. The selection of materials is quite logical, each of them is used in its most appropriate constructive purpose. The range of different finishes and colors is meant to be easily matched with any kind of contemporary residential or contract project.

# Woak

# MORASI

# 22





Morasi  
bench



**Morasi  
bench**

Design: Simon Morasi  
Piperčić  
Material: Walnut or oak  
Surface treatment: Lacquer or oil

**Dimensions**

W		D		H
140 cm	x	36 cm	x	47 cm
160 cm	x	36 cm	x	47 cm
180 cm	x	36 cm	x	47 cm
200 cm	x	36 cm	x	47 cm
220 cm	x	36 cm	x	47 cm





Morasi  
bench

A melting pot DNA where skills originate from crossed cultures and combine with the woodworking tradition of the land where the raw material comes from. Woak symbolises the strength of a company and the desire to open up to the new with an almost nomad vocation to travel and absorb knowledge from all over the world and then mix it with the original heritage of craftsmanship carpentry.

Instead of products, we create "pieces", crafted with great care for the users as well the environment. We are passionate about working with the warmth of solid wood, especially oak and walnut, and attach great importance to sustainable raw materials.

# Woak

NERVOSA designed by Francesco Faccin. The project is based on traditional chairs typical of the Tyrolean and South Tyrolean area. They have a very interesting feature from a structural point of view: the seat is the key element that unites all the pieces. The "Nervosa" chair formally moves away from that typology but retains its constructive spirit while being made entirely with cnc technology. The material is entirely solid wood, which is perfect for the precision workmanship and mechanical characteristics required by this design. The chair is designed to be made of natural wood but with some aniline-treated variants that still allow the grain to show through.

# NERVOSA

# 22



NERVOSA  
chair

NERVOSA  
dining  
table

NERVOSA  
chair with  
armrest

NERVOSA  
stool

HAKU  
self standing  
storage



NERVOSA  
chair



NERVOSA  
chair



NERVOSA  
chair

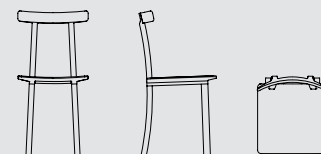

**NERVOSA  
chair**

Design: Francesco Faccin  
Material: Walnut, oak or  
painted wood  
Surface treatment: Lacquer or oil

**Dimensions**

W		D		H
40 cm	x	44 cm	x	83.5 cm





NERVOSA  
chair

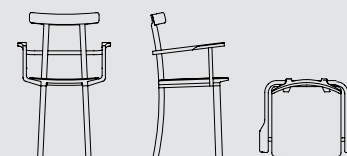

**NERVOSA  
chair with  
armrest**

Design: Francesco Faccin  
Material: Walnut, oak or  
painted wood  
Surface treatment: Lacquer or oil

**Dimensions**

W		D		H
54 cm	x	44 cm	x	83.5 cm



NERVOSA  
chair



NERVOSA  
bar stool



**NERVOSA  
bar stool**

Design: Francesco Faccin  
Material: Walnut, oak or painted wood  
Surface treatment: Lacquer or oil

**Dimensions**

W		D		H
40 cm	x	40 cm	x	88 cm

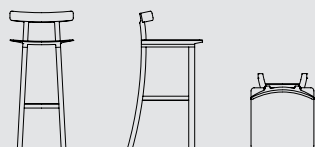

**NERVOSA  
stool**

Design: Francesco Faccin  
Material: Walnut, oak or painted wood  
Surface treatment: Lacquer or oil

**Dimensions**

W		D		H
40 cm	x	40 cm	x	45 cm

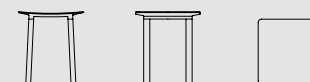



## NERVOSA bench

Design: Francesco Faccin  
 Material: Walnut or oak  
 Surface treatment: Lacquer or oil

### Dimensions

W		D		H
160 cm	x	40 cm	x	45 cm
180 cm	x	40 cm	x	45 cm
200 cm	x	40 cm	x	45 cm
220 cm	x	40 cm	x	45 cm

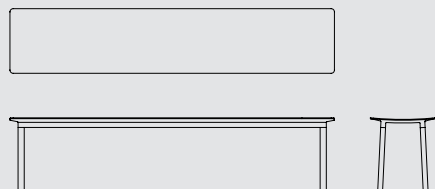

## NERVOSA dining table

Design: Francesco Faccin  
 Material: Walnut or oak  
 Surface treatment: Lacquer or oil

### Dimensions

W		D		H
180 cm	x	85 cm	x	75 cm
200 cm	x	85 cm	x	75 cm
220 cm	x	85 cm	x	75 cm
240 cm	x	90 cm	x	75 cm

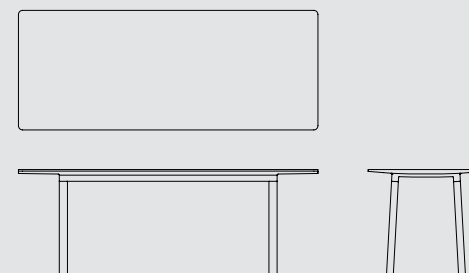



NERVOSA  
dining  
table



NERVOSA  
chair



A melting pot DNA where skills originate from crossed cultures and combine with the woodworking tradition of the land where the raw material comes from. Woak symbolises the strength of a company and the desire to open up to the new with an almost nomad vocation to travel and absorb knowledge from all over the world and then mix it with the original heritage of craftsmanship carpentry.

Instead of products, we create "pieces", crafted with great care for the users as well the environment. We are passionate about working with the warmth of solid wood, especially oak and walnut, and attach great importance to sustainable raw materials.

Designed by Woak.

The theme is the minimalist lines applied to pieces of furniture from the past. The collection aims to offer a new interpretation of classic objects through a regeneration of the style with Woak's own processing techniques. The intent is to dismantle the common places of traditional forms, eliminating frills and elements that are too decorative to make the object contemporary and at the same time functional. Ninas consists of a console, a sidesboard and a coffee table where the clarity of the shape has been contrasted with the marble top that gives character and prestige. The dining table is an eclectic element of the collection to play with the other pieces around it.

# Woak

# NINAS

# 22





NINAS  
console

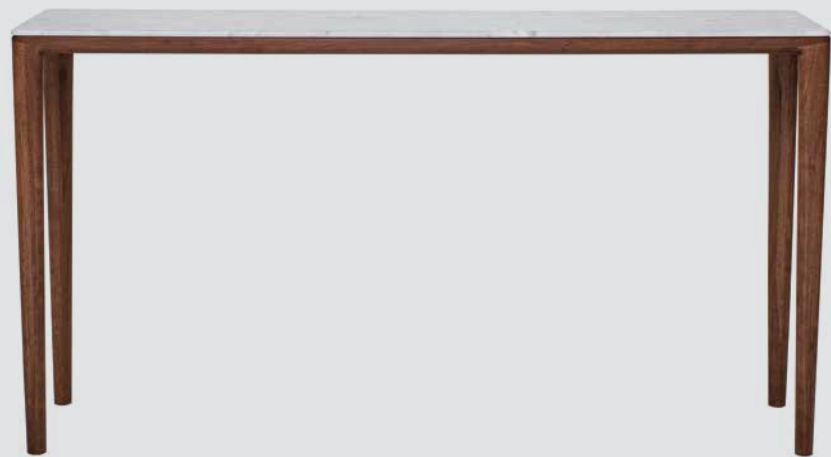

**NINAS  
console**

Design: Woak  
 Material: Walnut or oak  
 Marble, Terrazzo  
 Surface treatment: Oil

**Dimensions**

W		D		H
110 cm	x	35 cm	x	75 cm
140 cm	x	35 cm	x	75 cm

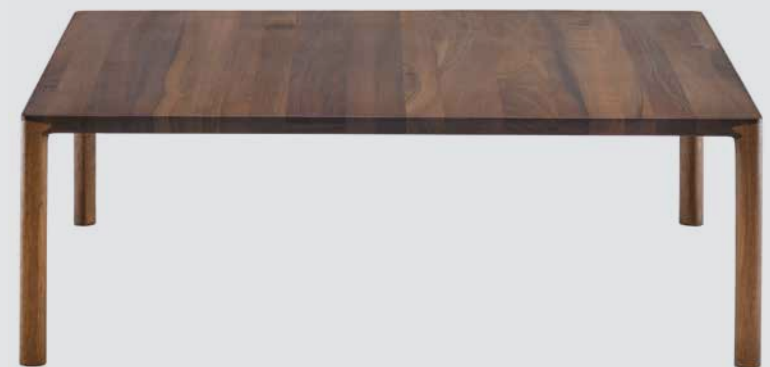
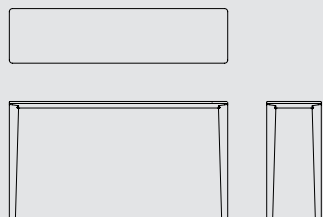

**NINAS  
coffee table**

Design: Woak  
 Material: Walnut or oak  
 Surface treatment: Oil

**Dimensions**

W		D		H
45 cm	x	45 cm	x	50 cm
70 cm	x	70 cm	x	30 cm
90 cm	x	90 cm	x	30 cm
120 cm	x	55 cm	x	40 cm
140 cm	x	55 cm	x	40 cm

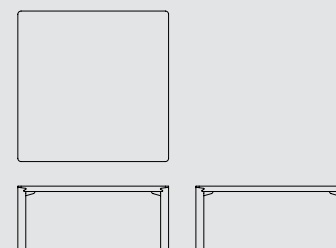

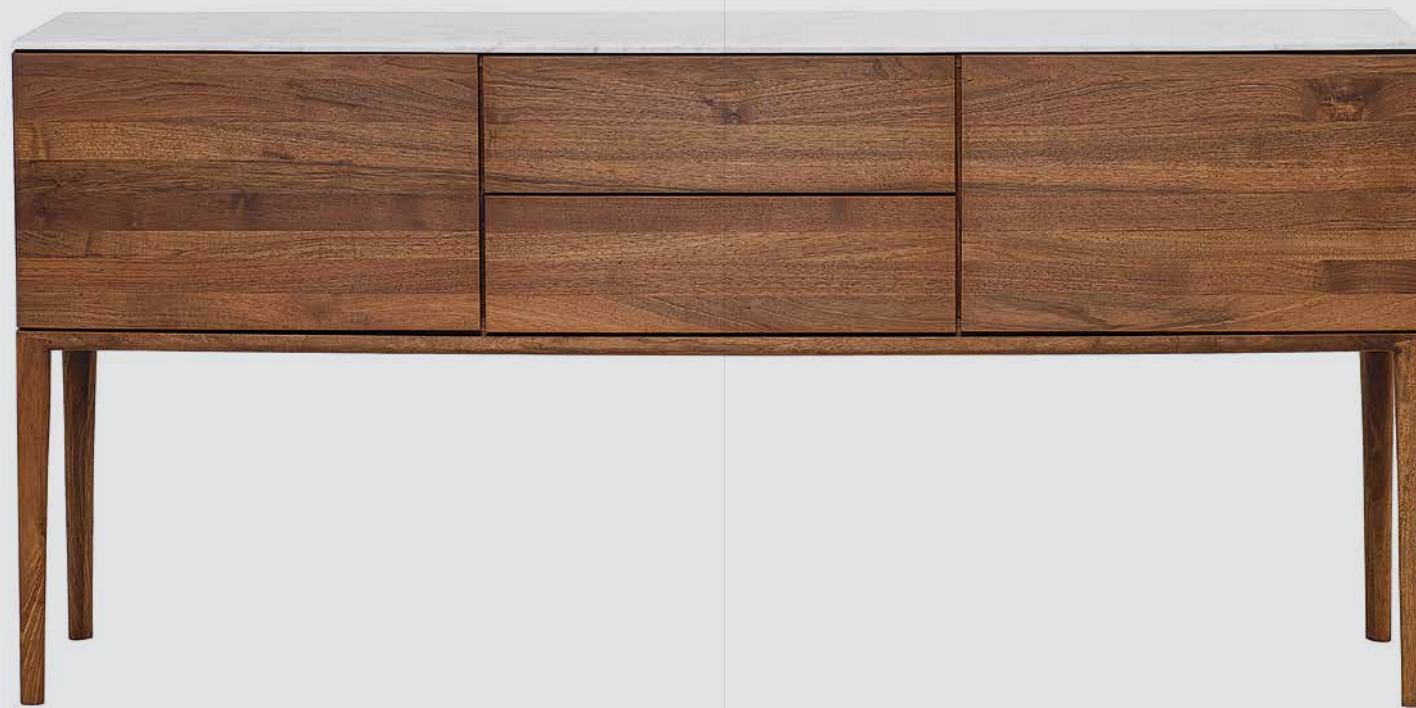

**NINAS  
sideboard**

Design: Woak  
 Material: Walnut or oak  
 Marble, Terrazzo  
 Surface treatment: Oil

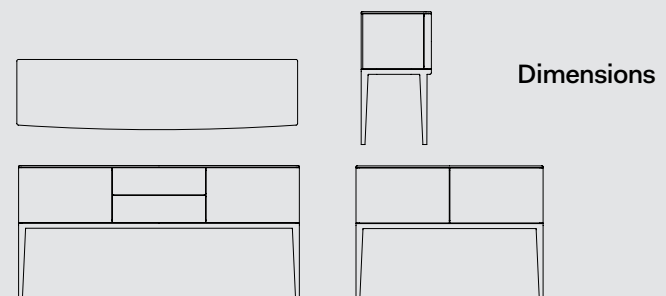

W		D		H
120 cm	x	45 cm	x	85 cm
2 doors				
120 cm	x	45 cm	x	85 cm
3 drawers				
180 cm	x	45 cm	x	85 cm
2 drawers & 2 doors				

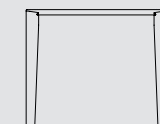
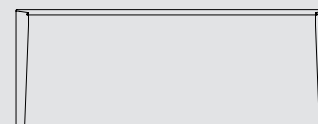
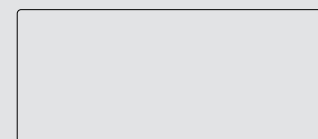
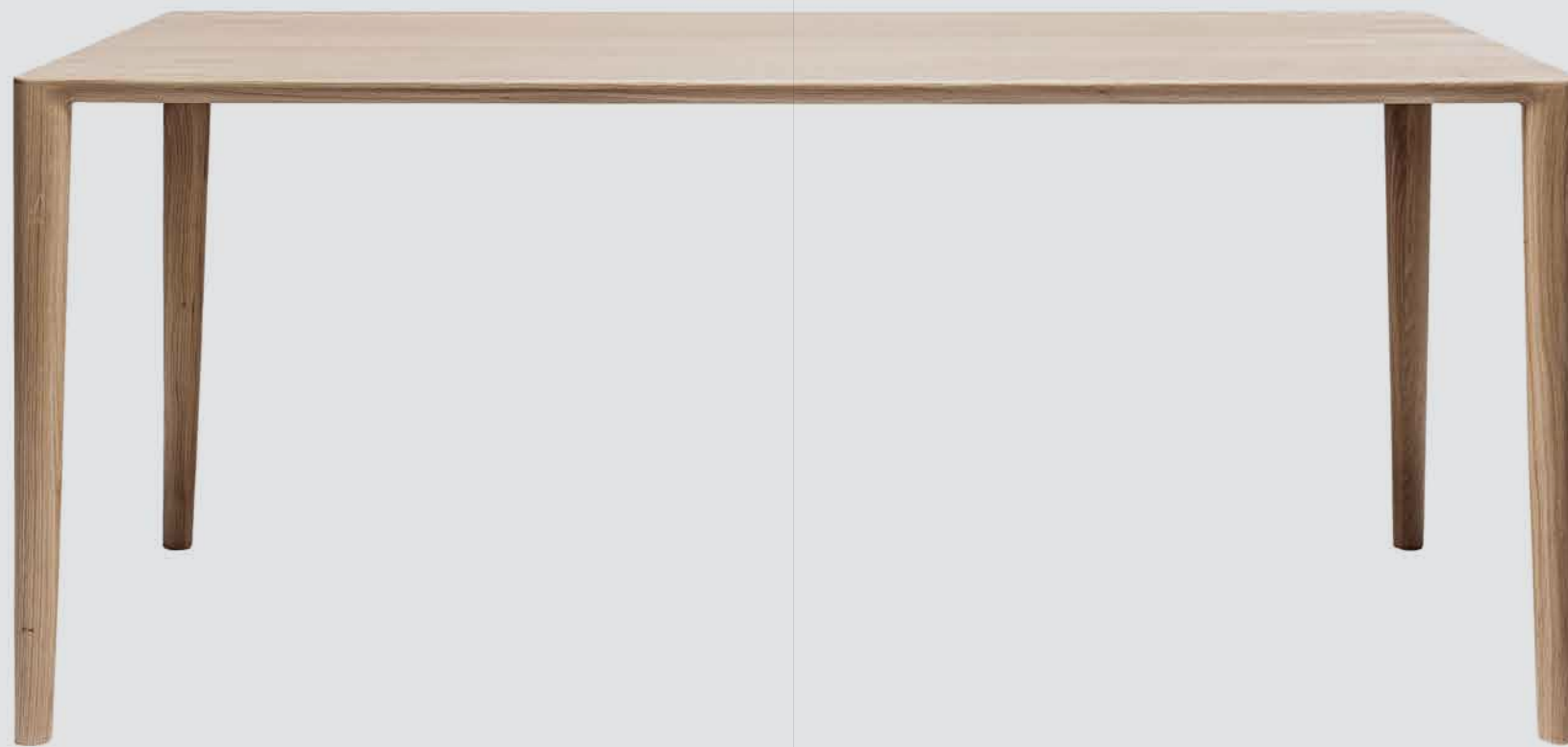

**NINAS  
dining table**

**Dimensions**

Design: Woak  
Material: Walnut or oak  
Surface treatment: Oil

W		D		H
160 cm	x	90/100 cm	x	75 cm
180 cm	x	90/100 cm	x	75 cm
200 cm	x	90/100 cm	x	75 cm
220 cm	x	90/100 cm	x	75 cm



**NINAS**  
side table

Design: Woak  
Material: Walnut or oak  
Marble, Terrazzo  
Surface treatment: Oil

**Dimensions**

W		D		H
45 cm	x	45 cm	x	45 cm

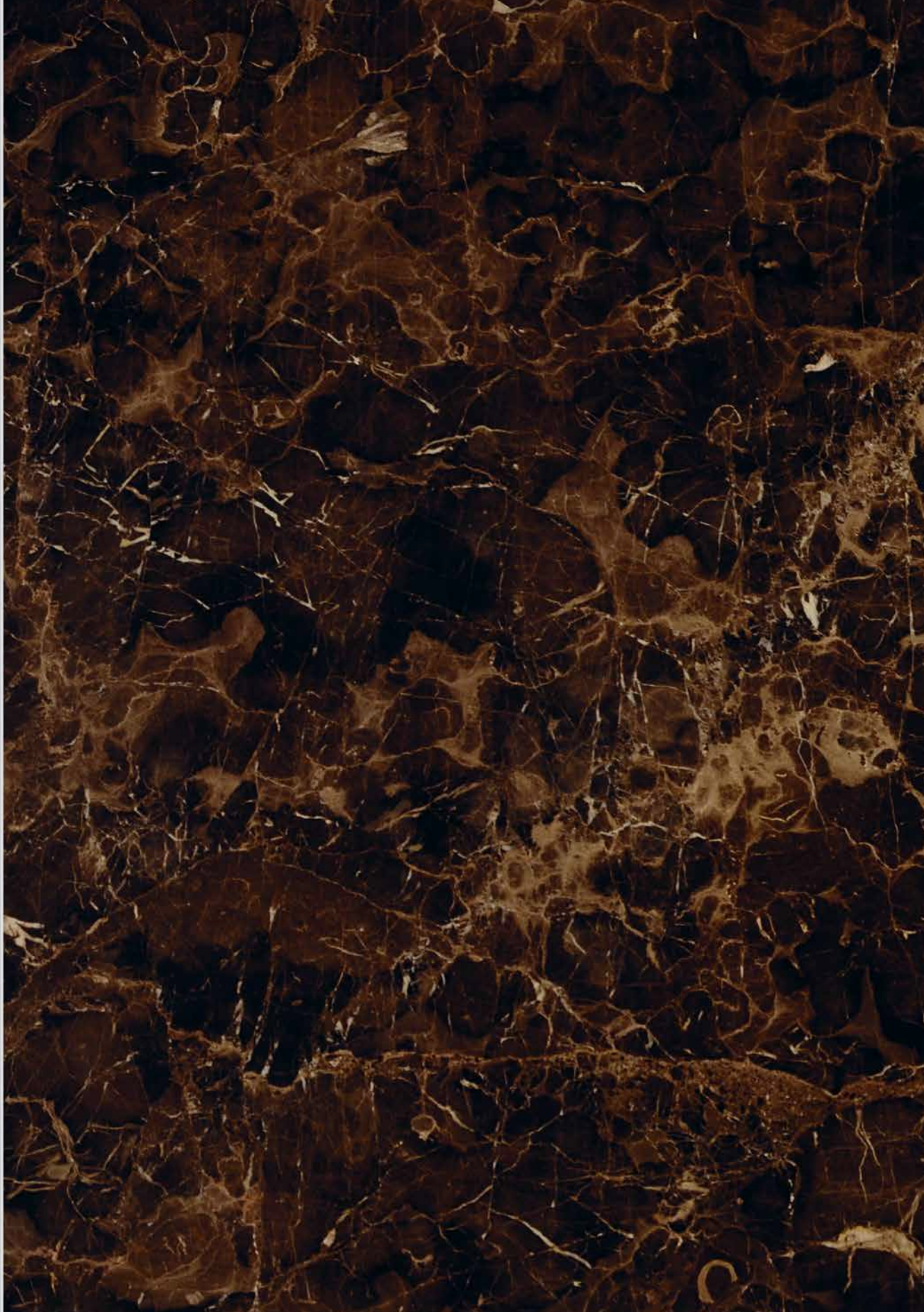

A melting pot DNA where skills originate from crossed cultures and combine with the woodworking tradition of the land where the raw material comes from. Woak symbolises the strength of a company and the desire to open up to the new with an almost nomad vocation to travel and absorb knowledge from all over the world and then mix it with the original heritage of craftsmanship carpentry.

Instead of products, we create "pieces", crafted with great care for the users as well the environment. We are passionate about working with the warmth of solid wood, especially oak and walnut, and attach great importance to sustainable raw materials.

# Woak

Designed by Rainer Bachschmid.  
For my dialogue with nature, wood offers the maximum potential. It is alive, mouldable, stable, sustainable and always radiates naturalness. There are only a few producers who have recognised this potential and know how to use it. That craftsmanship in handling those attributes for example is also reflected in the potential of Woak. My products made of wood should retain their natural value. Clever details highlight this expression and emphasize Woak's craftsmanship. I prefer to work with breathable oils and am fascinated by translucent colors that highlight the structure of the wood. In addition, a sensitive mix with other materials and colors creates even more expression and uniqueness.

# ORGANIC

# LAVADO



ORGANIC  
dining table

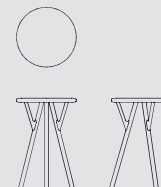

**Dimensions**

W	D	H
Ø 35 cm	x	x 42.5 cm
Ø 35 cm	x	x 47.5 cm
Ø 35 cm	x	x 52.5 cm





**ORGANIC  
dining table**

Design: Rainer Bachschmid  
Material: Walnut or oak  
Surface treatment: Lacquer or oil

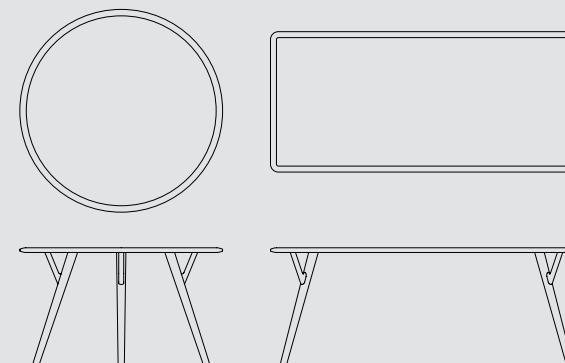

**Dimensions**

W		D		H
160 cm	x	90/100 cm	x	75 cm
180 cm	x	90/100cm	x	75 cm
200 cm	x	90/100 cm	x	75 cm
220 cm	x	90/100 cm	x	75 cm
240 cm	x	90/100 cm	x	75 cm
300 cm	x	100 cm	x	75 cm
Ø 130 cm			x	75 cm
Ø 150 cm			x	75 cm



**LAVADO  
dining table**

Design: Rainer Bachschmid  
Material: Walnut or oak  
Surface treatment: Lacquer or oil

**Dimensions**

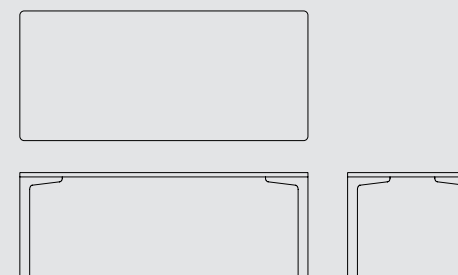

W		D		H
160 cm	x	90/100 cm	x	75 cm
180 cm	x	90/100 cm	x	75 cm
200 cm	x	90/100 cm	x	75 cm
220 cm	x	90/100 cm	x	75 cm
240 cm	x	90/100 cm	x	75 cm
300 cm	x	100 cm	x	75 cm



LAVADO  
dining table

A melting pot DNA where skills originate from crossed cultures and combine with the woodworking tradition of the land where the raw material comes from. Woak symbolises the strength of a newly independent country and the desire to open up to the new with an almost nomad vocation to travel and absorb knowledge from all over the world and then mix it with the original heritage of craftsmanship carpentry.

Instead of products, we create "pieces", crafted with great care for the users as well the environment. We are passionate about working with the warmth of solid wood, especially oak and walnut, and attach great importance to sustainable raw materials.

Designed by Andrea Steidl REPETA is a symbol of the know-how and technology of Woak; their excellence in the industry of wood working. During my visit to the manufacturing facilities, I was immediately captivated by the technology and manufacturing facilities where Woak demonstrates their mastery. The industrial structure seems very efficient in which long lines of carpenters and workers transform a rough trunk by assembling perfect, linear and smooth planks into solid wood tops, dining tables or furniture; the noblest quality of wooden furniture. They are characterized by the furniture industry as well as the tradition of cabinet-making and high-quality carpentry. The combination of milling machine technology and the experience of old carpenters who have loved and cultivated woodworking for 30 years made it clear to me that narrating this process within a single product was a priority. I had to find a language

that would exploit this context and its production qualities. This is why Repeta has a strong character, it is the character and strength of the workers and of a land where solid wood has always been part of the production of quality furniture and objects. The repetition of pieces of the same shape and size for me was the mirror of the industrial repetition of a single piece which within Woak is a must to obtain a complex and uniform product of solid wood. The Repeta collection was designed to transform their industrial culture into complex furniture with a strong and unique aesthetic. The collection is composed of containers and sideboards with an assembled, faceted and grooved structure, which is very complex to make. It was just as complex to find the assembly model that must be carried out by the expert hands of the carpenters. The collection creates objects with geometric motifs declined in different shades of wood used to contain the objects of our unique passions.

# Woak

# REPETA

# 22



BRIONI  
chair

WHERRY  
dining table

REPETA 01  
cupboard



REPETA 01  
cupboard



REPETA 01  
cupboard

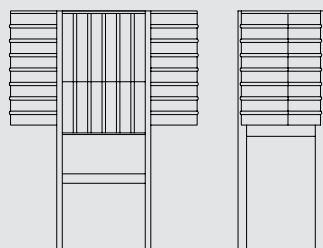
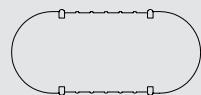

**REPETA 01  
cupboard**

Design: Andrea Steidl  
 Material: Walnut or oak  
 Marble or Terrazzo  
 Surface treatment: Oil

**Dimensions**

W		D		H
100 cm	x	43 cm	x	120 cm

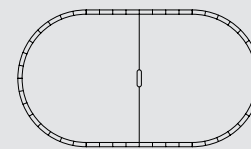

**REPETA 04  
coffee table**

Design: Andrea Steidl  
 Material: Walnut or oak  
 Marble, Terrazzo  
 or Wood  
 Surface treatment: Oil

**Dimensions**

W		D		H
142 cm	x	80 cm	x	36 cm



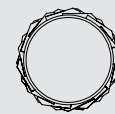
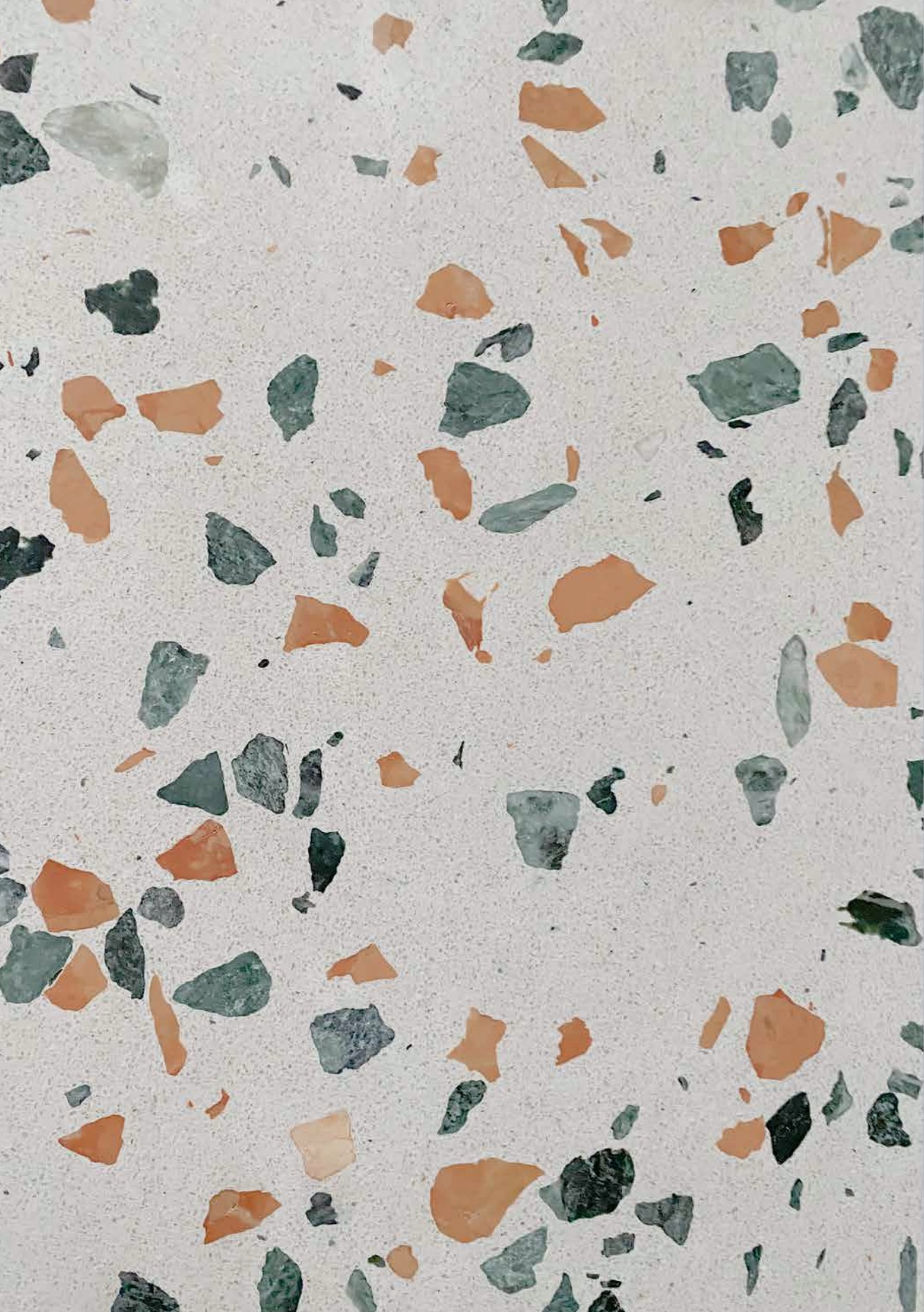

**REPETA 10  
side table**

Design: Andrea Steid  
Material: Walnut or oak  
Copper, Marble,  
Terrazzo or Wood  
Surface treatment: Oil

**Dimensions**

W		D		H
65 cm	x	65 cm	x	36 cm

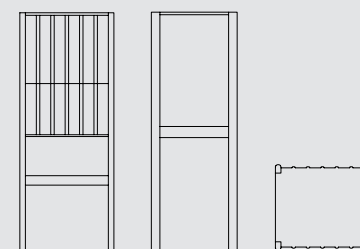

**REPETA 02  
cupboard**

Design: Andrea Steidl  
Material: Walnut or oak  
Marble, Terrazzo  
Surface treatment: Oil

**Dimensions**

W		D		H
51 cm	x	43 cm	x	120 cm



REPETA 03  
cupboard

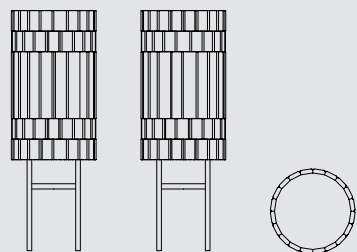

**REPETA 03  
cupboard**

Design: Andrea Steidl  
 Material: Walnut or oak  
 Metal  
 Surface treatment: Oil

**Dimensions**

W		D		H
50 cm	x	50 cm	x	140 cm

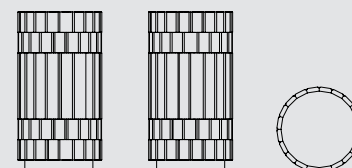

**REPETA 03  
cupboard**

Design: Andrea Steid  
 Material: Walnut or oak  
 Metal  
 Surface treatment: Oil

**Dimensions**

W		D		H
50 cm	x	50 cm	x	92 cm



REPETA 03  
cupboard



REPETA 03  
cupboard



REPETA 03  
cupboard



A melting pot DNA where skills originate from crossed cultures and combine with the woodworking tradition of the land where the raw material comes from. Woak symbolises the strength of a company and the desire to open up to the new with an almost nomad vocation to travel and absorb knowledge from all over the world and then mix it with the original heritage of craftsmanship carpentry.

Instead of products, we create "pieces", crafted with great care for the users as well the environment. We are passionate about working with the warmth of solid wood, especially oak and walnut, and attach great importance to sustainable raw materials.

Designed by Matteo Zorzenoni SAGUARO is a coat hanger that acts as a functional decorative element inside the house. Made entirely of solid wood, it has four adjustable arms that, depending on the need, can modify its volume until it resembles a Cactus from which it takes its name.

# Woak

# SAGUARO

# 22





DIORAMA  
console



SAGUARO  
hanger



BRIONI  
bar stool  
high



SAGUARO  
hanger

SAGUARO  
hanger

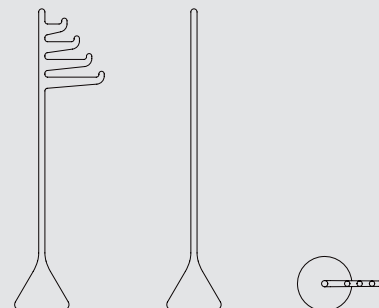

SAGUARO  
hanger

Dimensions

Design: Matteo Zorzenoni  
Material: Walnut or oak  
Surface treatment: Lacquer or oil

W		D		H
50,5 cm	x	60 cm	x	170 cm



SAGUARO  
hanger



A melting pot DNA where skills originate from crossed cultures and combine with the woodworking tradition of the land where the raw material comes from. Woak symbolises the strength of a company and the desire to open up to the new with an almost nomad vocation to travel and absorb knowledge from all over the world and then mix it with the original heritage of craftsmanship carpentry.

Instead of products, we create "pieces", crafted with great care for the users as well the environment. We are passionate about working with the warmth of solid wood, especially oak and walnut, and attach great importance to sustainable raw materials.

Designed by Isabel Ahm.  
Tria is inspired by antique milking stools. Tria transforms the milking chair typology into a contemporary high quality coffee table, minimal and with a clever construction. It is made from walnut and a hand crafted glass table top. The details are tactile and invites you to touch the table. It is an inviting table, that nourishes your senses.

# Woak

# TRIA

# 22



TRIA  
coffee table



TRIA  
coffee table

TRIA  
coffee table

Design: Isabel Ahm  
Material: Walnut or oak  
Table top: Parsol  
Glass or Wood  
Surface treatment: Oil

Dimensions

W	D	H
Ø 80 cm	x	x 42 cm

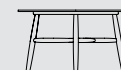
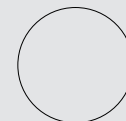





TRIA  
coffee table

A melting pot DNA where skills originate from crossed cultures and combine with the woodworking tradition of the land where the raw material comes from. Woak symbolises the strength of a company and the desire to open up to the new with an almost nomad vocation to travel and absorb knowledge from all over the world and then mix it with the original heritage of craftsmanship carpentry.

Instead of products, we create "pieces", crafted with great care for the users as well the environment. We are passionate about working with the warmth of solid wood, especially oak and walnut, and attach great importance to sustainable raw materials.

Designed by Andrea Steidl WHERRY is composed of intricate rounded boards, the result of a refined artisan woodwork. It draws inspiration from the traditional English boats of the same name and the fluid shapes of their oars which, in a transitional game between the shaft and the paddle, are enriched with details. In the chair, the boards are repeated, marking the rhythm of the backrest and harmoniously enveloping those who sit down, as in traditional Windsor armchairs.

# Woak

# WHERRY

# 22



WHERRY  
Chair

WING  
coffee table

WHERRY  
dining table



**WHERRY  
Chair**

Design: Andrea Steidl  
Material: Walnut, oak or painted wood  
Surface treatment: Lacquer or oil

**Dimensions**

W		D		H
60 cm	x	55 cm	x	76 cm





**WHERRY  
Armchair**

Design: Andrea Steidl  
Material: Walnut, oak or painted wood  
Surface treatment: Lacquer or oil

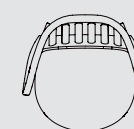
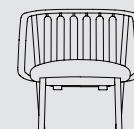

**Dimensions**

W		D		H
74 cm	x	69 cm	x	72 cm

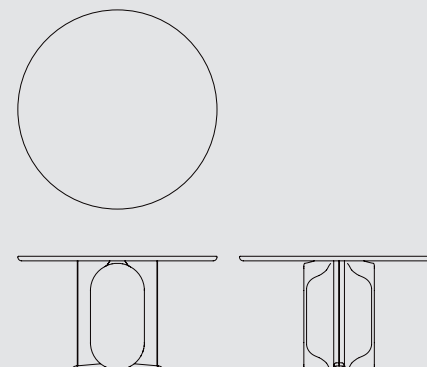

**WHERRY  
dining table**

Design: Andrea Steidl  
Material: Walnut, oak or painted wood legs  
Surface treatment: Lacquer or oil

**Dimensions**

R	H
Ø 130 cm	x 75 cm



WHERRY  
dining table



**WHERRY  
dining table**

Design: Andrea Steidl  
Material: Walnut, oak or  
painted wood legs  
Surface treatment: Lacquer or oil

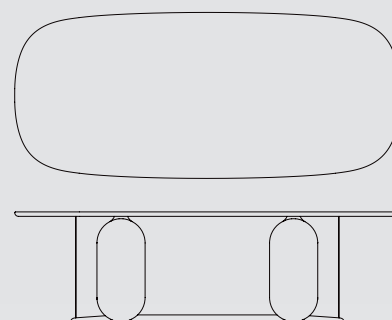

**Dimensions**

W		D		H
220 cm	x	106 cm	x	75 cm
260 cm	x	112 cm	x	75 cm
300 cm	x	112 cm	x	75 cm





WHERRY  
dining table



WHERRY  
dining table



A melting pot DNA where skills originate from crossed cultures and combine with the woodworking tradition of the land where the raw material comes from. Woak symbolises the strength of a company and the desire to open up to the new with an almost nomad vocation to travel and absorb knowledge from all over the world and then mix it with the original heritage of craftsmanship carpentry.

Instead of products, we create "pieces", crafted with great care for the users as well the environment. We are passionate about working with the warmth of solid wood, especially oak and walnut, and attach great importance to sustainable raw materials.

# Woak

Designed by Constance Guisset WING is a collection of tables combining full lines and aerial contours. The fluid shapes draw a sculptural object, between obvious presence and lightness. The declension in four sizes and the integration of two levels let free-field to different use.

# WING

# 22



WHERRY  
Chair



WING  
coffee table



WHERRY  
dining table



WING  
coffee table

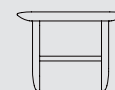
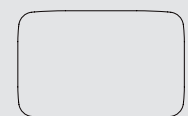

**WING  
coffee table**

Design: Constance Guisset  
Material: Walnut or oak  
Surface treatment: Oil

**Dimensions**

W		D		H
70 cm	x	45 cm	x	33 cm
90 cm	x	60 cm		33 cm



**WING**  
coffee table



**WING**  
coffee table

Design: Constance Guisset  
Material: Walnut or oak  
Surface treatment: Oil

**Dimensions**

W		D		H
45 cm	x	45 cm	x	45 cm



**WING**  
coffee table

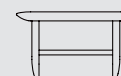
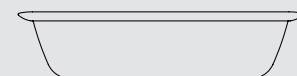
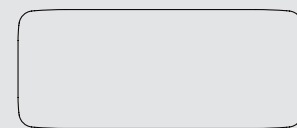

**WING**  
coffee table

**Dimensions**

Design: Constance Guisset  
Material: Walnut or oak  
Surface treatment: Oil

W		D		H
120 cm	x	50 cm		28 cm





WING  
coffee table

A melting pot DNA where skills originate from crossed cultures and combine with the woodworking tradition of the land where the raw material comes from. Woak symbolises the strength of a newly independent country and the desire to open up to the new with an almost nomad vocation to travel and absorb knowledge from all over the world and then mix it with the original heritage of craftsmanship carpentry.

Instead of products, we create “pieces”, crafted with great care for the users as well the environment. We are passionate about working with the warmth of solid wood, especially oak and walnut, and attach great importance to sustainable raw materials.

**Woak**

**23**

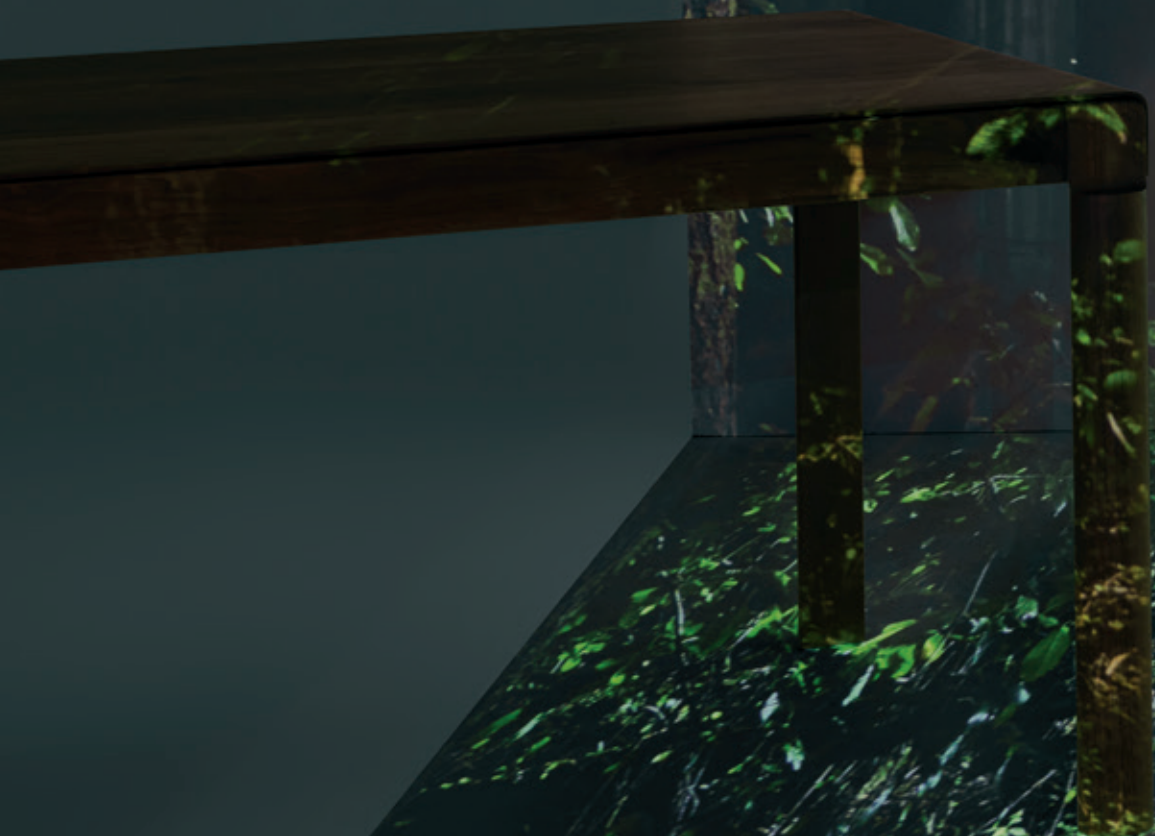

BURLY  
Dining table



BURLY  
Chair



WEDGED  
wall wood rug



ORIGINAL  
box 1

Designed by Matteo Fogale. The idea behind the pieces is to produce a familiar collection of furniture showcasing the strength and honesty of solid wood. Large sections of material are abruptly transformed into thinner sections creating a contrast of thick and thin, heavy and light. In the shelving system, different widths of vertical planes play with positive and negative space, visually heavy and light at the same time.

# BURLY

# 23



BURLY  
chair



**BURLY  
chair**

Design: Matteo Fogale  
Material: Walnut, oak  
or beech  
Surface treatment: Lacquer or oil

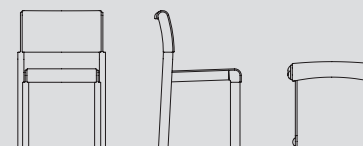

**Dimensions**

W		D		H
51 cm	x	50 cm	x	80 cm



BURLY  
chair

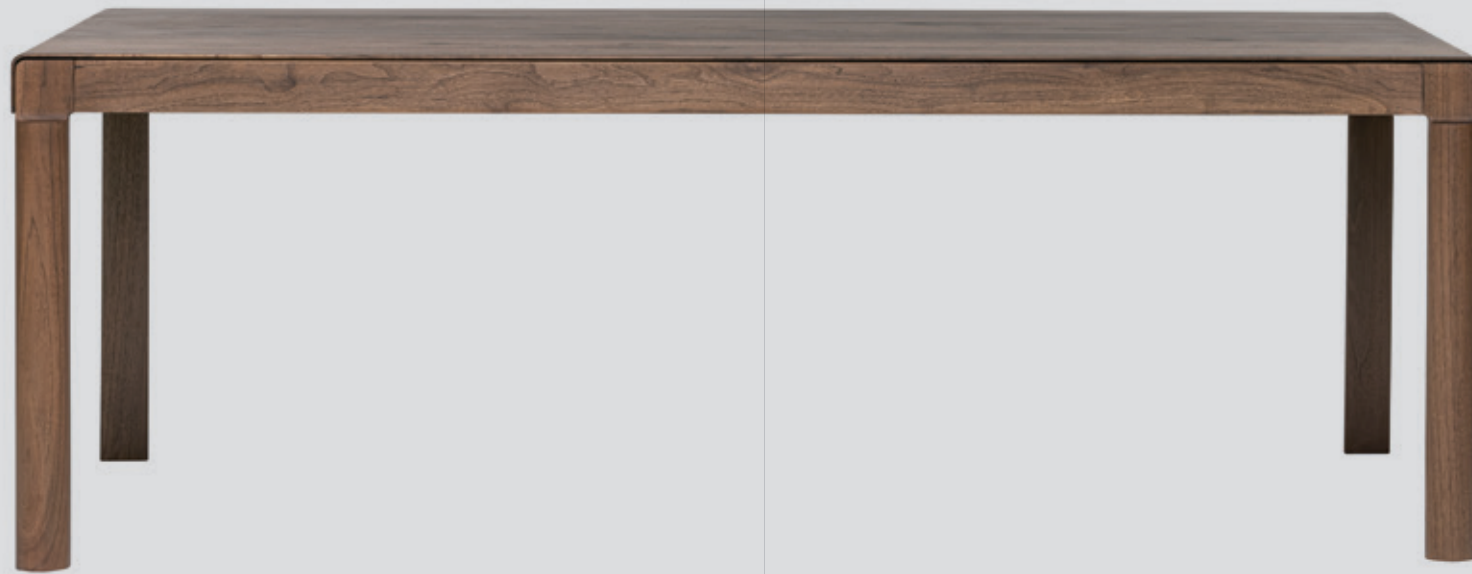

**BURLY**  
dining table

Design: Matteo Fogale  
Material: Walnut or oak  
Surface treatment: Lacquer or oil

**Dimensions**

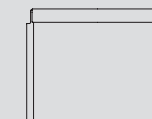
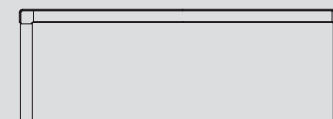
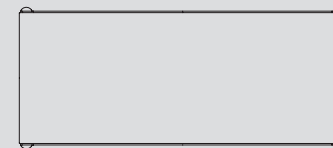

W		D		H
160 cm	x	95 cm	x	76 cm
180 cm	x	95 cm	x	76 cm
200 cm	x	95 cm	x	76 cm
220 cm	x	95 cm	x	76 cm
240 cm	x	95 cm	x	76 cm



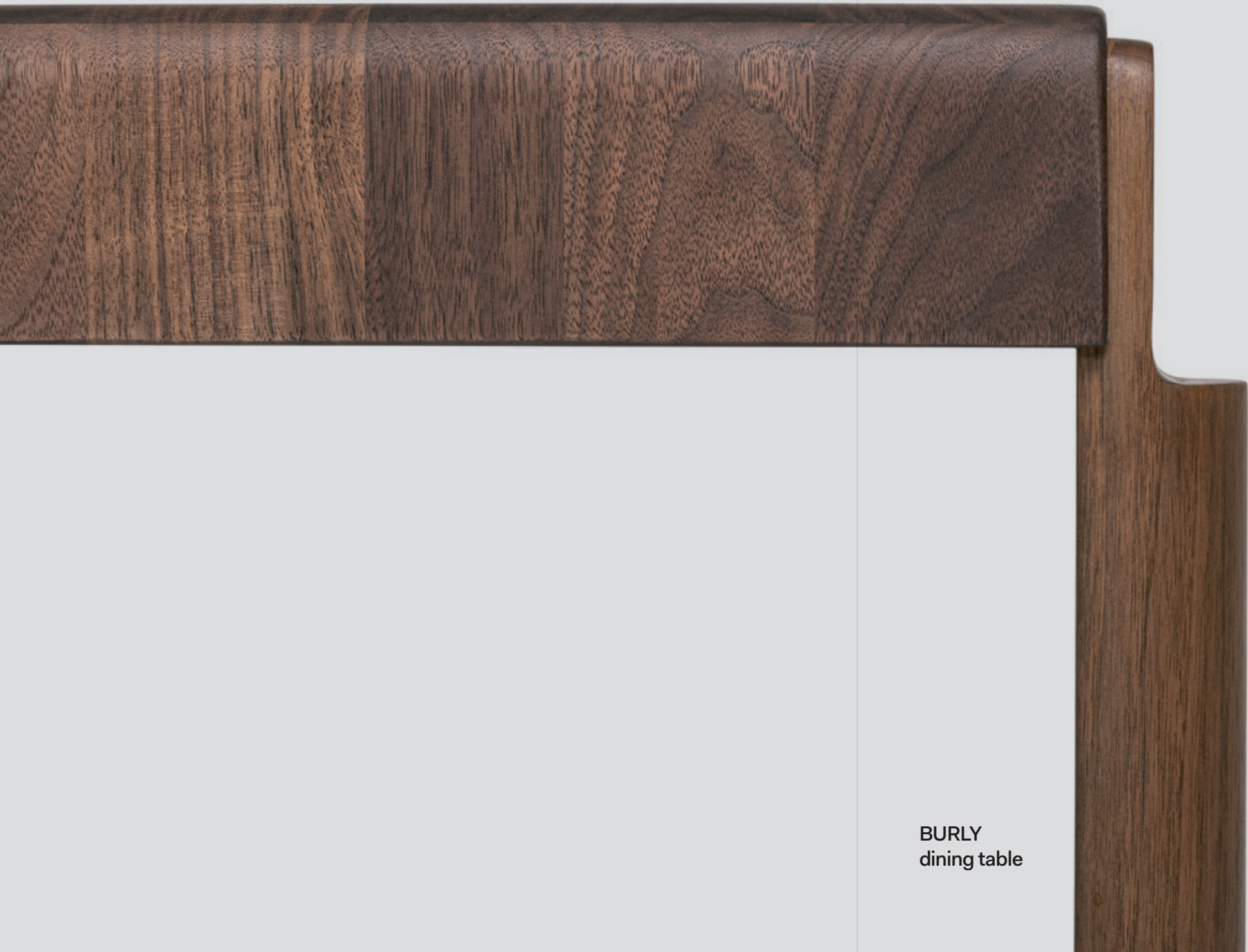

BURLY  
dining table

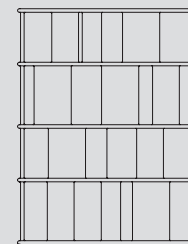
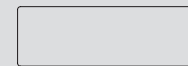

**BURLY  
highboard**

Design: Matteo Fogale  
 Material: Walnut or oak  
 Surface treatment: Oil

**Dimensions**

W		D		H
120 cm	x	40 cm	x	160 cm

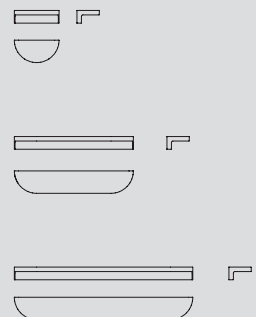

**BURLY  
shelf**

Design: Matteo Fogale  
 Material: Walnut or oak  
 Surface treatment: Oil

**Dimensions**

W		D		H
30 cm	x	15 cm	x	8.5 cm
80 cm	x	15 cm	x	8.5 cm
120 cm	x	15 cm	x	8.5 cm

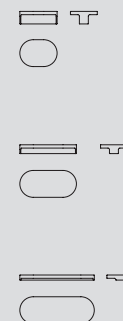

**BURLY  
tray**

Design: Matteo Fogale  
 Material: Walnut or oak  
 Surface treatment: Oil

**Dimensions**

W		D		H
25 cm	x	18 cm	x	8.4 cm
38 cm	x	18 cm	x	5.9 cm
50 cm	x	18 cm	x	3.4 cm



BURLY  
tray

Designed by Zoran Jedrejčić.  
A new dining table completes the Brioni collection and like the rest of the family, it is geometrically determined by straight, clean lines and surfaces with slightly curved corners and joints. It exudes stability and its form and proportions seattle in our memories. Brioni table is detachable, crafted with great care for the final users and environment and suitable for home and contract use.

# BRIONI

# 23

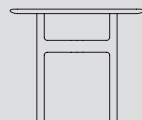
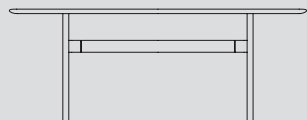
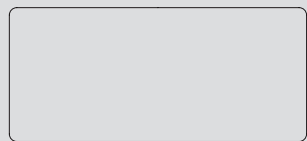
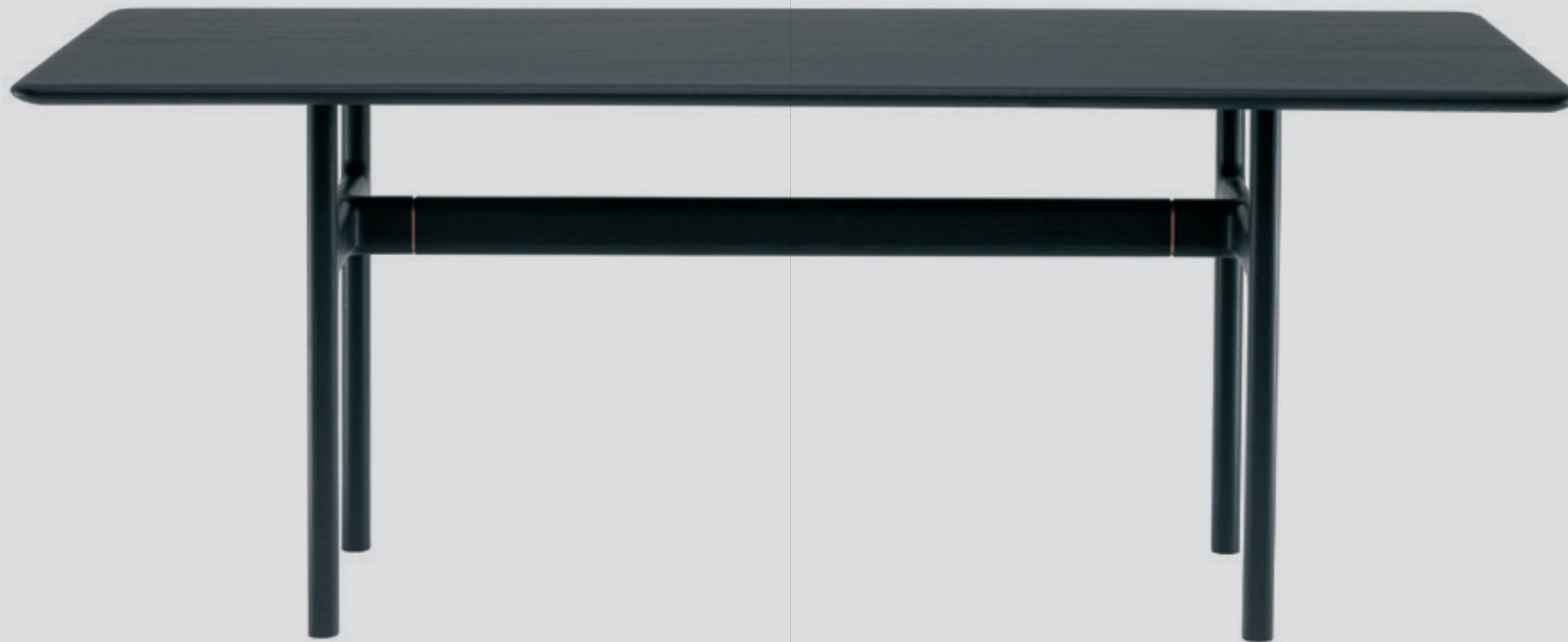

**BRIONI**  
dining table

Design: Zoran Jedrejčić  
Material: Walnut or oak  
Surface treatment: Lacquer or oil

**Dimensions**

W		D		H
160 cm	x	90 cm	x	75 cm
180 cm	x	90 cm	x	75 cm
200 cm	x	90 cm	x	75 cm
220 cm	x	90 cm	x	75 cm
240 cm	x	90 cm	x	75 cm

W		D		H
160 cm	x	100 cm	x	75 cm
180 cm	x	100 cm	x	75 cm
200 cm	x	100 cm	x	75 cm
220 cm	x	100 cm	x	75 cm
240 cm	x	100 cm	x	75 cm
300 cm	x	100 cm	x	75 cm



BRIONI  
dining table

Designed by Zoran Jedrejčić.  
The idea behind Galeb corner storage system is to use all those underrated spaces like corners and angles to give them another life and meaning. Galeb transforms any corner in your public or private space into "art corner" to collect favorite books, objects, wines, or just let the children put their favorite toys.

# GALEB

# 23





SAGUARO  
hanger

GALEB  
Corner Storage System

GINCANA  
tray nuts

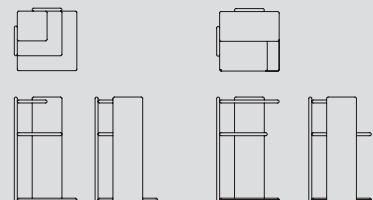

**GALEB  
corner storage  
system / low**

**Dimensions**

Design: Zoran Jedrejčić  
Material: Walnut or oak  
Surface treatment: Oil

W		D		H
42 cm	x	42 cm	x	71 cm

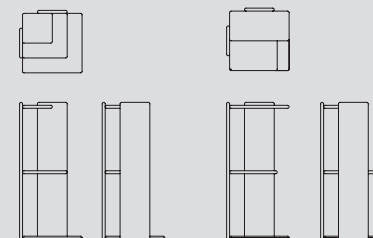

**GALEB  
corner storage  
system / medium**

**Dimensions**

Design: Zoran Jedrejčić  
Material: Walnut or oak  
Surface treatment: Oil

W		D		H
42 cm	x	42 cm	x	93 cm



GALEB  
corner storage  
system / low

Designed by Matteo Zorzenoni, Gincana is a collection of modular fruit bowls made of solid oak wood painted in different colours.

Thanks to the grooves, it can accommodate different types of fruit and become a fun table decoration with different form combinations.

# GINCANA

# 23



GINCANA  
tray nuts



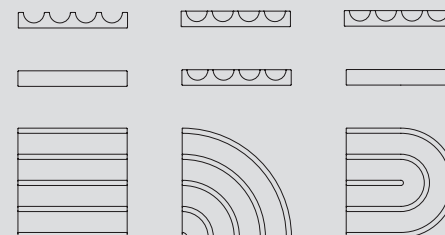

**GINCANA  
tray nuts 3**

Design: Matteo Zorzenoni  
 Material: Walnut or oak  
 Surface treatment: Oil

**Dimensions**

W		D		H
18 cm	x	18 cm	x	3 cm

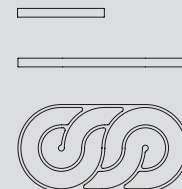

**GINCANA  
fruit trays 1**

**Dimensions**

Design: Matteo Zorzenoni  
 Material: Walnut or oak  
 Surface treatment: Oil

W		D		H
51 cm	x	26 cm	x	3 cm

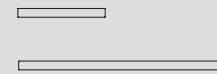

**GINCANA  
fruit trays 2**

Design: Matteo Zorzenoni  
Material: Walnut or oak  
Surface treatment: Oil

**Dimensions**

W		D		H
62 cm	x	26 cm	x	3 cm



Designed by Cristophe De La Fontaine, Haku-Mini is a set of wooden centrepieces that capture the essence of their larger cabinet counterparts. Inspired by architectural models, Mini-Haku features the same unique design principle of axial repetition as the original Haku. The result is a set of centrepieces that break away from the ordinary and challenge conventional norms with their subtle yet distinctive presence. Whether used as a tray, pedestal or basket, Mini-Haku's structure invites to experience in what way objects can interact with those miniatures.

# HAKU MINI

# 23



LEPIDA  
chair  
without  
armrest



HAKU MINI  
x, y, z

BRIONI  
dining table



HAKU MINI  
x, y, z



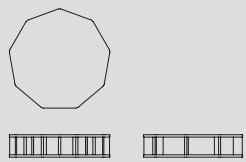

**HAKU MINI  
Z**

Design: Cristophe De La Fontaine  
 Material: Walnut or oak  
 Surface treatment: Oil

**Dimensions**

W		D		H
34 cm	x	34 cm	x	8 cm

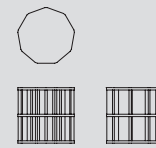

**HAKU MINI  
X**

Design: Cristophe De La Fontaine  
 Material: Walnut or oak  
 Surface treatment: Oil

**Dimensions**

W		D		H
19 cm	x	19 cm	x	19 cm

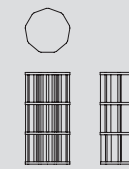

**HAKU MINI  
Y**

Design: Cristophe De La Fontaine  
 Material: Walnut or oak  
 Surface treatment: Oil

**Dimensions**

W		D		H
15 cm	x	15 cm	x	31 cm

Designed by Constance Guisset Lepida is a collection of chair and armchair made of solid wood. Their organic shapes unfold from the feet to form an elegant and comfortable sculpture. The two parts of the backrest reach each other without touching. They remind of petals as well as solid wooden paddles, or even of soft shoulder blades of an exoskeleton. A delicate piece connects them in a point, like a couture detail.

# LEPIDA

# 23



BURLY  
highboard



ORIGINAL  
dome  
coffret

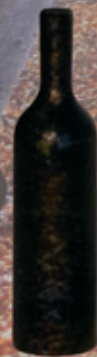

ORIGINAL  
bottle  
rolling pin



LEPIDA  
chair



LEPIDA  
chair  
without  
armrest



**LEPIDA  
chair  
without  
armrest**

Design: Constance Guisset  
Material: Walnut, oak or beech  
Surface treatment: Lacquer or oil

**Dimensions**

W		D		H
44 cm	x	48 cm	x	76 cm



**LEPIDA  
chair**

Design: Constance Guisset  
Material: Walnut, oak or beech  
Surface treatment: Lacquer or oil

**Dimensions**

W		D		H
60 cm	x	51 cm	x	78 cm







LEPIDA  
chair

Designed by Peter Gregson  
The original collection  
was inspired by one  
ordinary shipping box, an  
extraordinary bottle of wine,  
a homemade lemon cake, a  
hundredsomething grams of  
the finest chocolate, spicy  
cookies from somewhere and  
flatless flame from scented  
candle.

# ORIGINAL

# 23



ORIGINAL  
cup squizer



ORIGINAL  
rolling pin  
bottle



ORIGINAL  
table box



ORIGINAL  
tray box



ORIGINAL  
table box

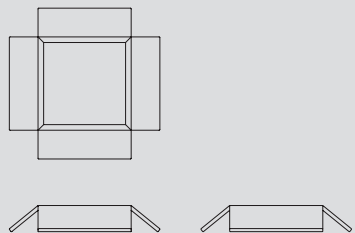
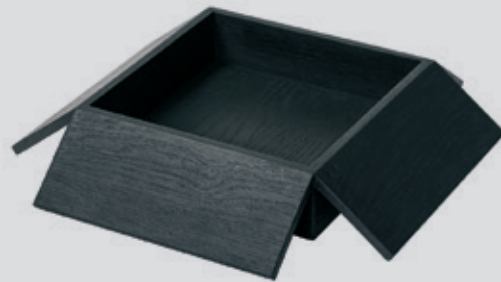

**ORIGINAL  
tray box**

Design: Peter Gregson  
 Material: Walnut or oak  
 Surface treatment: Oil

**Dimensions**

W		D		H
40 cm	x	40 cm	x	7 cm

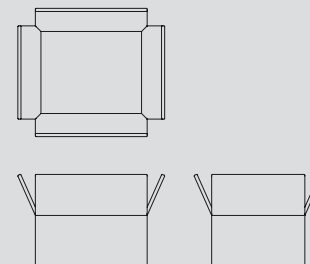

**ORIGINAL  
table box**

Design: Peter Gregson  
 Material: Walnut or oak  
 Surface treatment: Oil

**Dimensions**

W		D		H
40 cm	x	34 cm	x	25 cm



**ORIGINAL  
board in  
tray 1/2**

Design: Peter Gregson  
Material: Walnut or oak  
Surface treatment: Oil

**Dimensions**

W		D		H
26 cm	x	10 cm	x	1 cm
26 cm	x	21 cm	x	1 cm

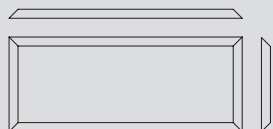

**ORIGINAL  
board in  
tray**

Design: Peter Gregson  
Material: Walnut or oak  
Surface treatment: Oil

**Dimensions**

W		D		H
26 cm	x	10 cm	x	2 cm
26 cm	x	21 cm	x	2 cm

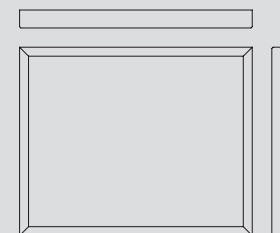

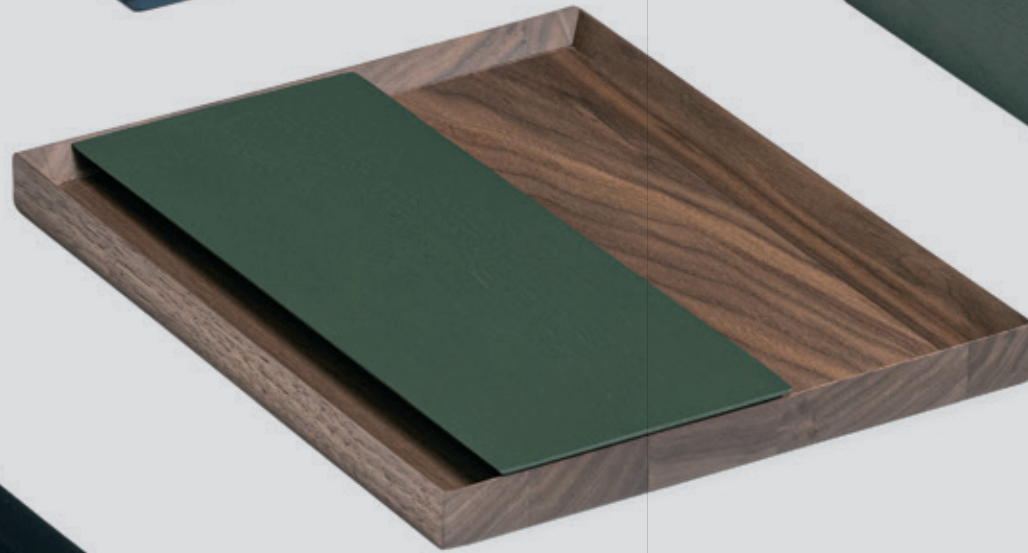
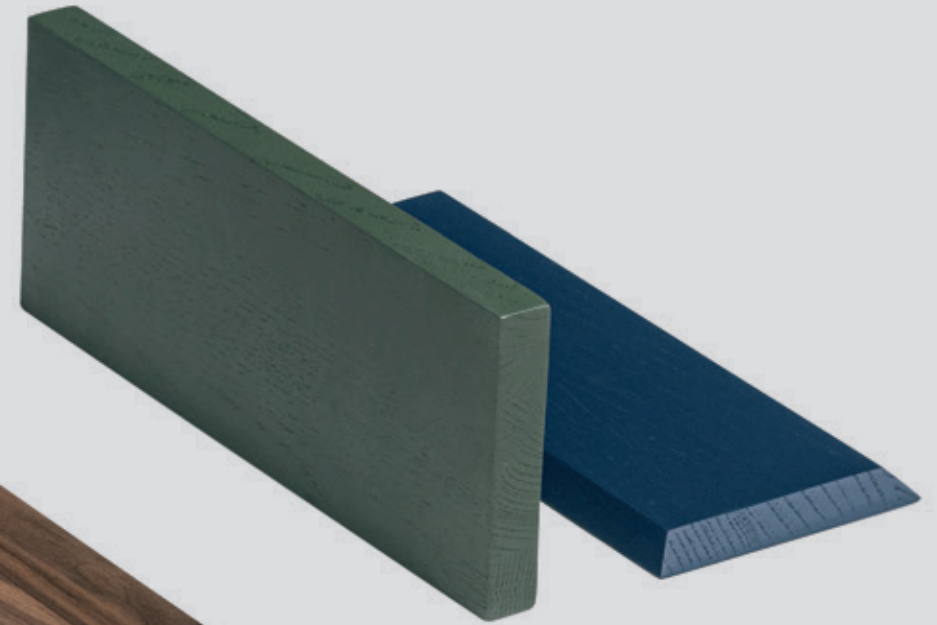
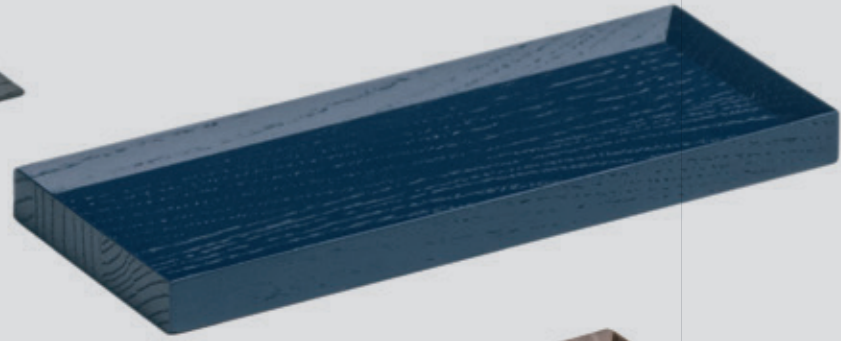
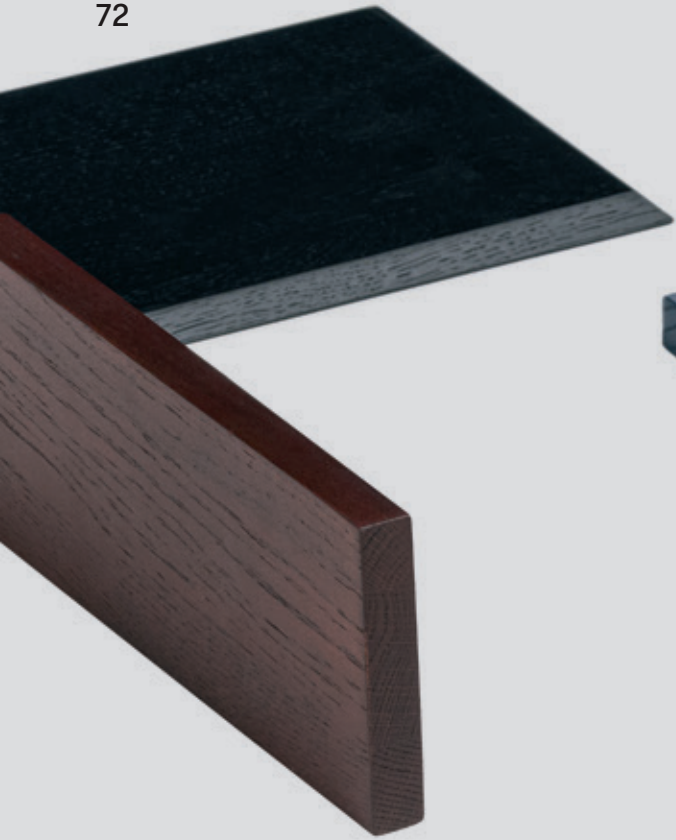

ORIGINAL  
board in tray

ORIGINAL  
board in tray ½



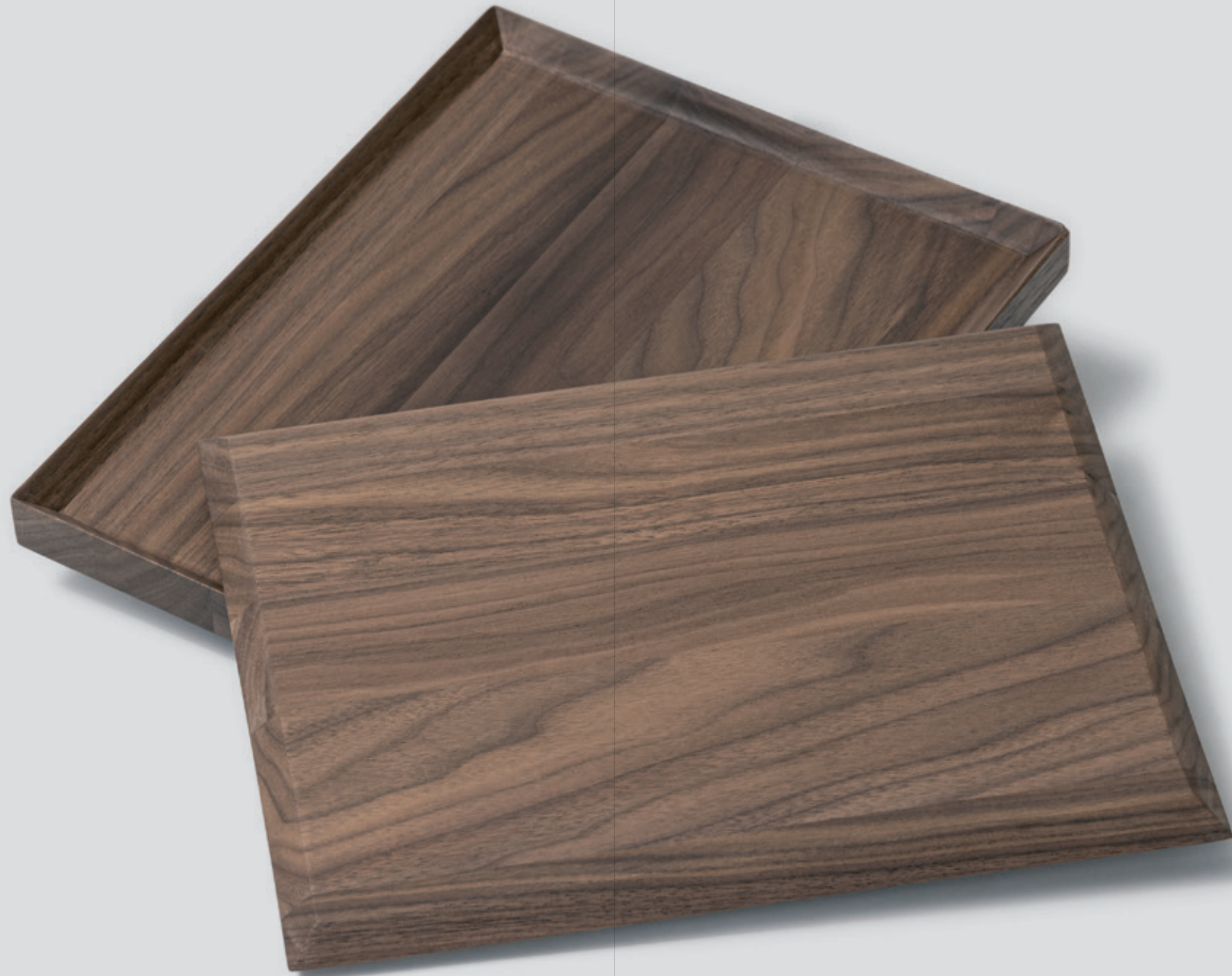

ORIGINAL  
board in tray





ORIGINAL  
dome  
coffret



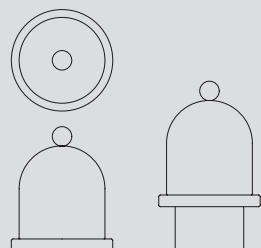

### ORIGINAL dome coffret

Design: Peter Gregson  
Material: Walnut or oak  
Surface treatment: Oil

#### Dimensions

W		D		H
13 cm	x	13 cm	x	15 cm

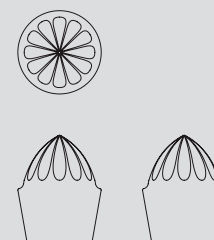

### ORIGINAL cup squizer

Design: Peter Gregson  
Material: Walnut or oak  
Surface treatment: Oil

#### Dimensions

W		D		H
7 cm	x	7 cm	x	9 cm

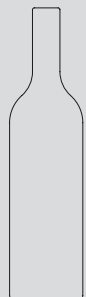
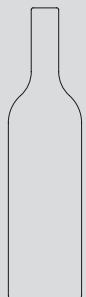
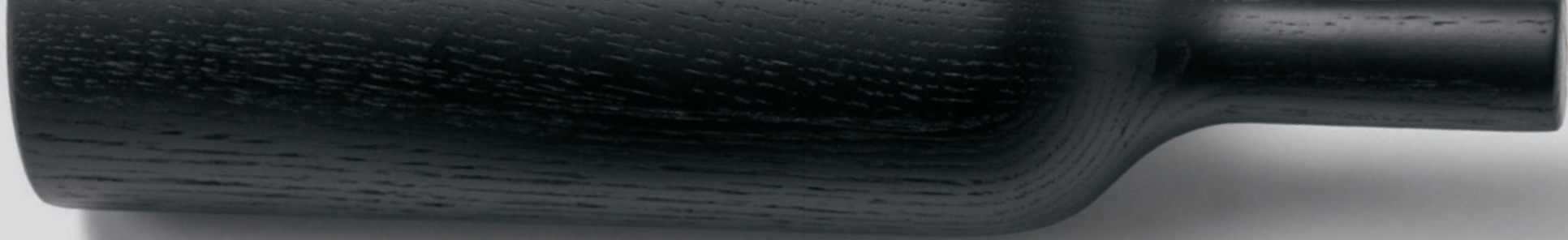

**ORIGINAL  
rolling pin  
bottle**

Design: Peter Gregson  
Material: Walnut or oak  
Surface treatment: Oil

**Dimensions**

W		D		H
8 cm	x	8 cm	x	32 cm

Designed by Raquel Pacchini.  
Interlocking wooden elements  
rhythmically overlap in a game  
of unexpected geometries.  
The natural raw material  
is the protagonist of the  
compositions, sometimes  
tinged with color becomes a  
painting. This metaphorical  
dialogue between solids  
and voids manifests the  
encounter of graphic and  
architectural approaches.

# UNEVEN

# 23



NERVOSA  
chair with  
armrest

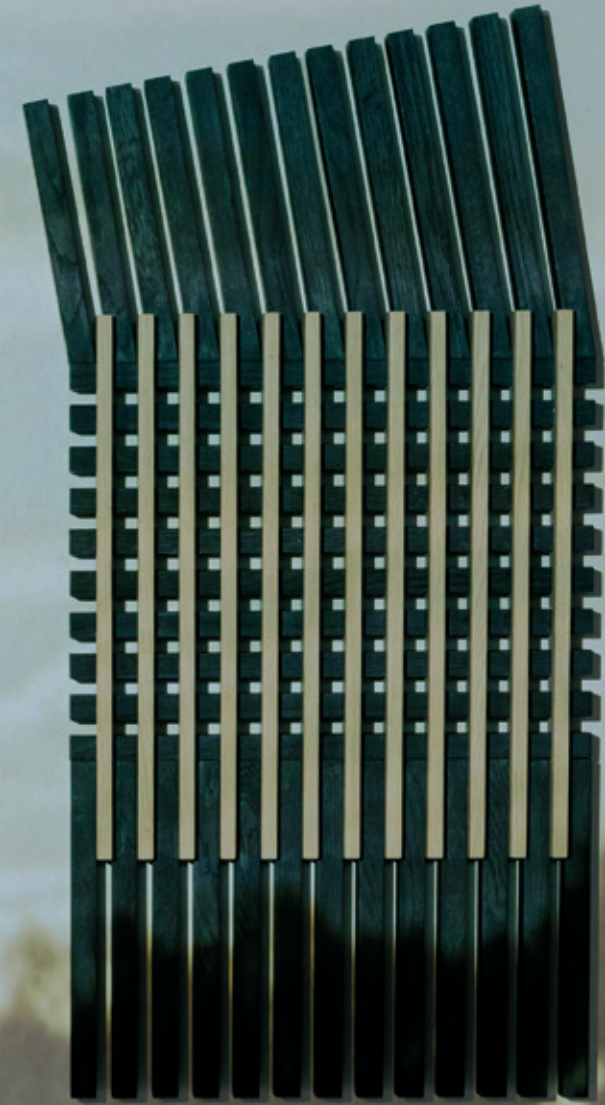

UNEVEN  
wall wood rug

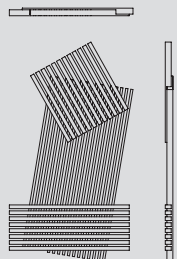
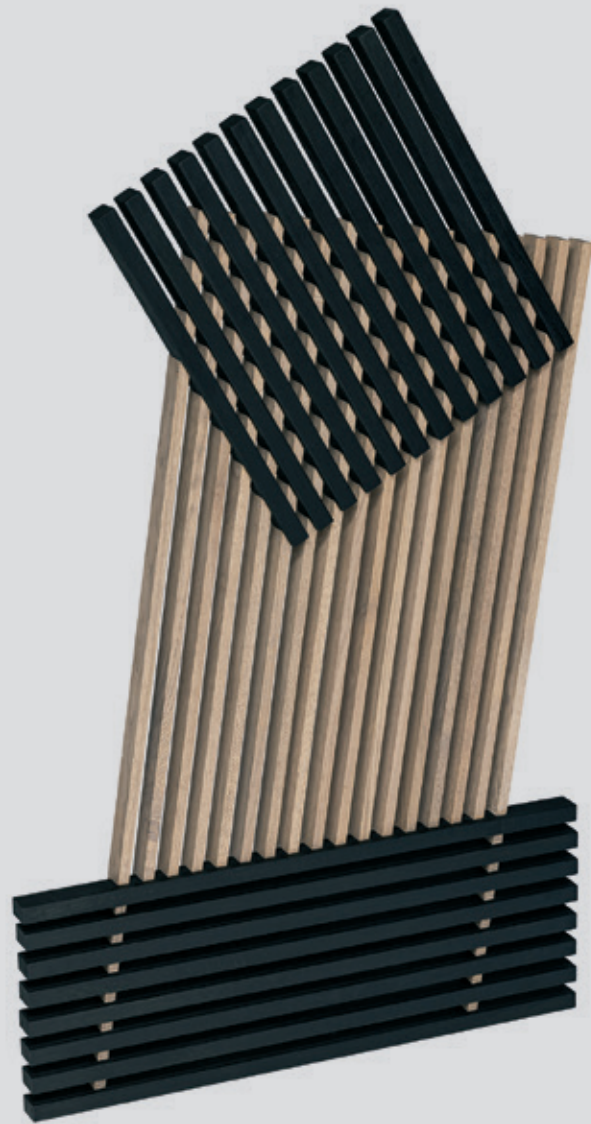

### UNEVEN wall wood rug

Design: Raquel Pacchini  
Material: Walnut or oak  
Surface treatment: Oil

#### Dimensions

W		D		H
140 cm	x	83 cm	x	5 cm

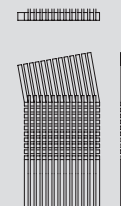
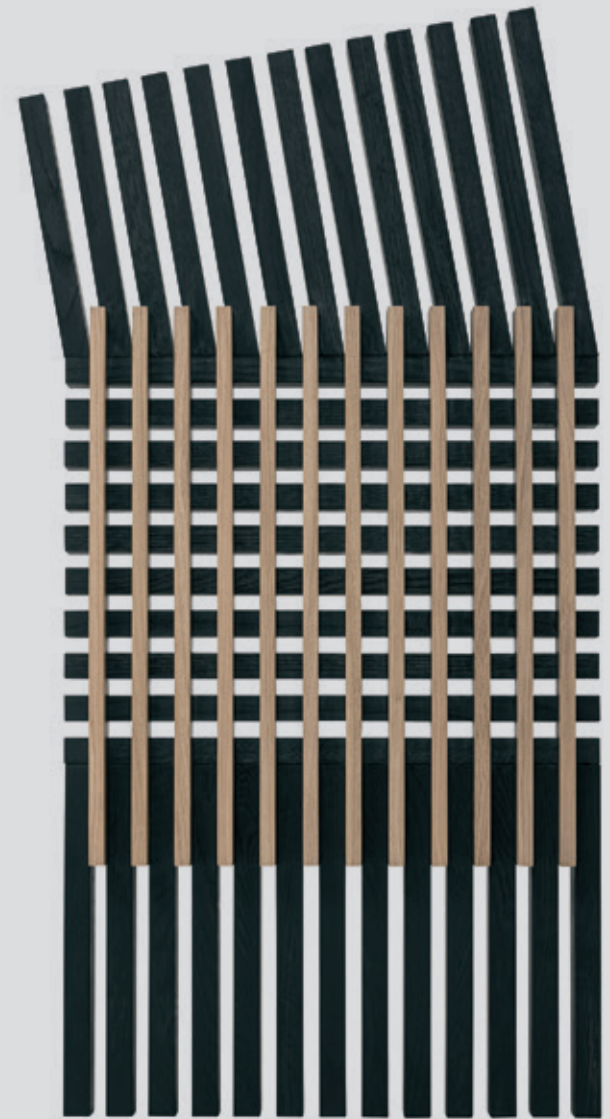

### UNEVEN wall wood rug

Design: Raquel Pacchini  
Material: Walnut or oak  
Surface treatment: Oil

#### Dimensions

W		D		H
105 cm	x	55 cm	x	8 cm

Designed by Matteo Cibic.  
Vesna is a mythological female character from Slavic cultures who represents spring. The beautiful Vesnas used to descend from their mountaintop palaces astride wooden cycles singing and discussing the fate of people and crops. They used to park their cycles on special wooden trestles that still bear their name today.

# VESNA

# 23

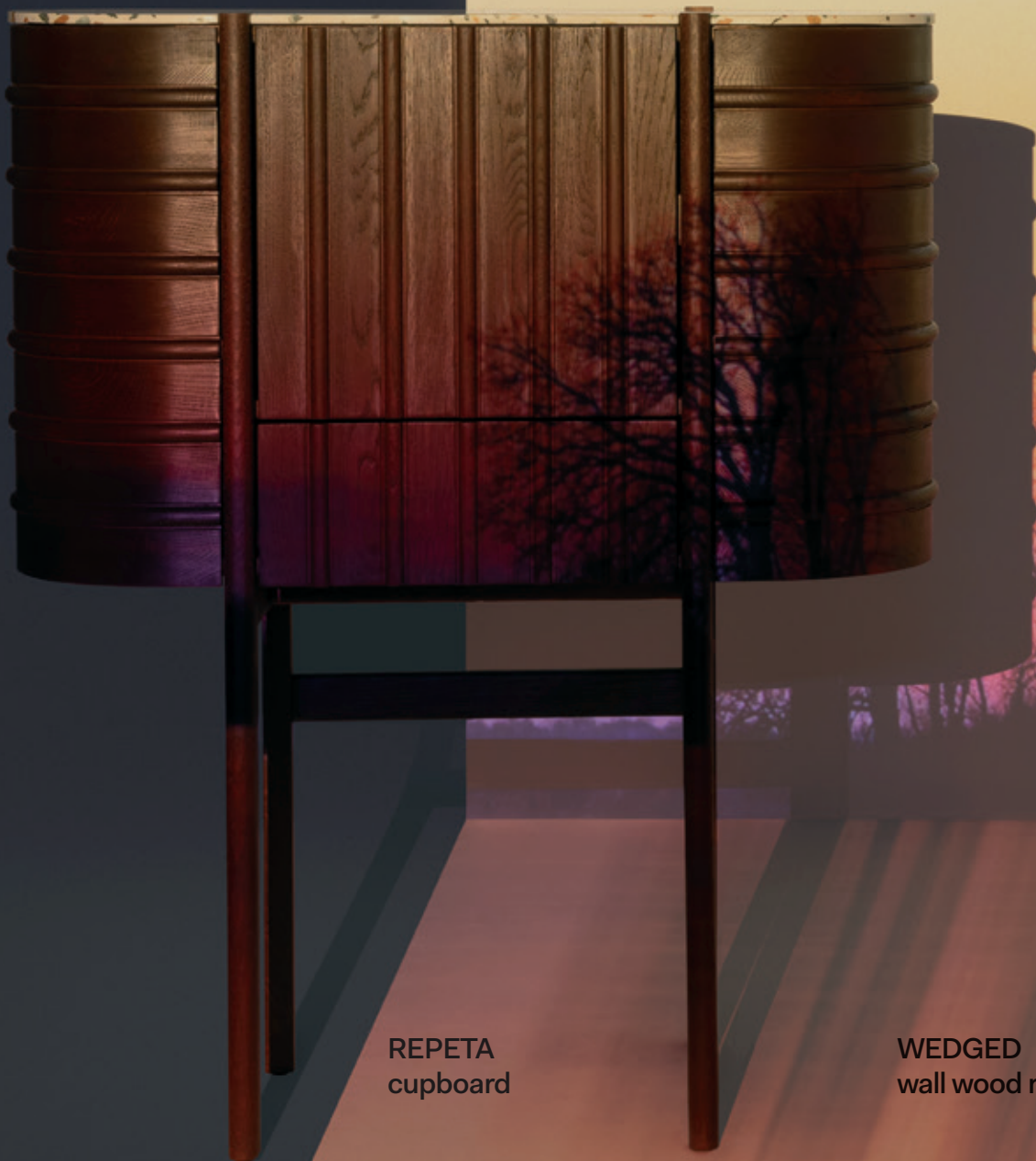

REPETA  
cupboard

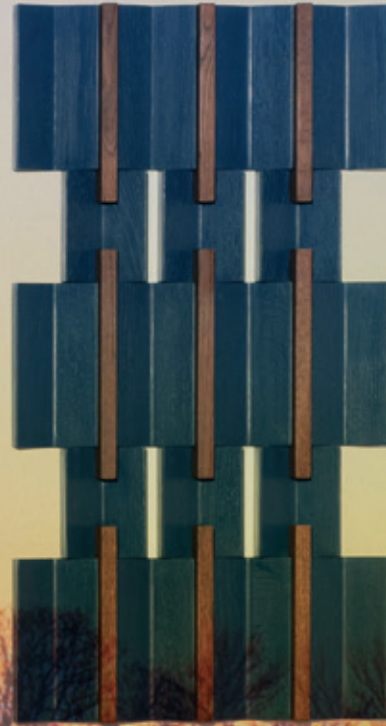

WEDGED  
wall wood rug



VESNA  
bike stand



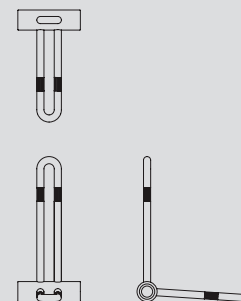

**VESNA  
bike stand**

Design: Matteo Cibic  
Material: Walnut or oak  
Surface treatment: Oil

**Dimensions**

W		D		H
50 cm	x	28 cm	x	65 cm

Designed by Raquel Pacchini.  
Interlocking wooden elements  
rhythmically overlap in a game  
of unexpected geometries.  
The natural raw material  
is the protagonist of the  
compositions, sometimes  
tinged with color becomes a  
painting. This metaphorical  
dialogue between solids  
and voids manifests the  
encounter of graphic and  
architectural approaches.

# WEDGED

# 23



WEDGED  
wall wood rug

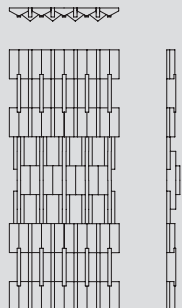

**WEDGED**  
wall wood rug

Design: Raquel Pacchini  
 Material: Walnut or oak  
 Surface treatment: Oil

**Dimensions**

W		D		H
150 cm	x	63 cm	x	8 cm

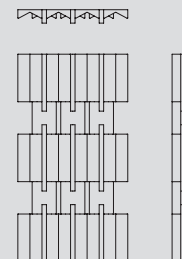
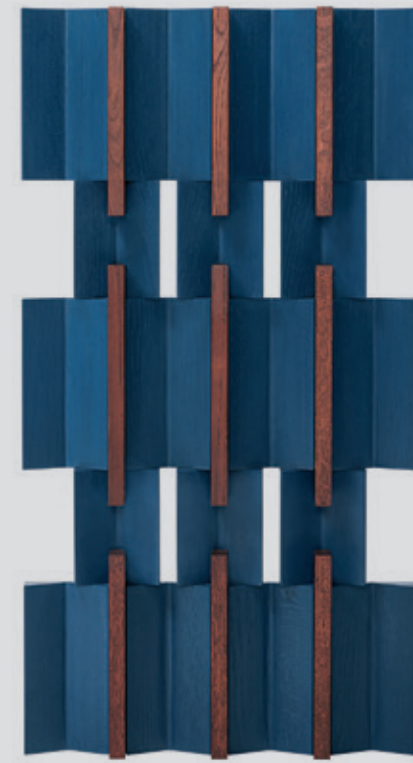

**WEDGED**  
wall wood rug

Design: Raquel Pacchini  
 Material: Walnut or oak  
 Surface treatment: Oil

**Dimensions**

W		D		H
93 cm	x	49 cm	x	6 cm

A meltin pot DNA where skills originate from crossed cultures and combine with the woodworking tradition of the land where the raw material comes from. Woak symbolises the strength of a company and the desire to open up to the new with an almost nomad vocation to travel and absorb knowledge from all over the world and then mix it with the original heritage of craftsmanship carpentry.

Instead of products, we create “pieces”, crafted with great care for the users as well the environment. We are passionate about working with the warmth of solid wood, especially oak and walnut, and attach great importance to sustainable raw materials.

# MATERIALS

23

wood



1 Oak White    2 Oak Sand    3 Oak Green    4 Oak Blue    5 Oak Black    6 Oak Red

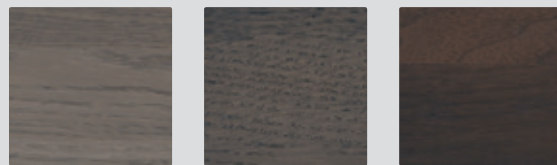

7 Oak Taupe    8 Oak Planked gray    9 Walnut Natural oil

mirror

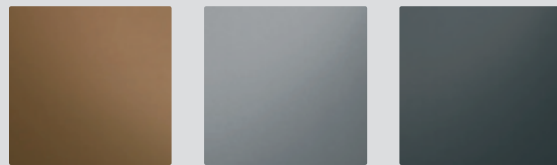

Bronze    Clear    Smoke

marble

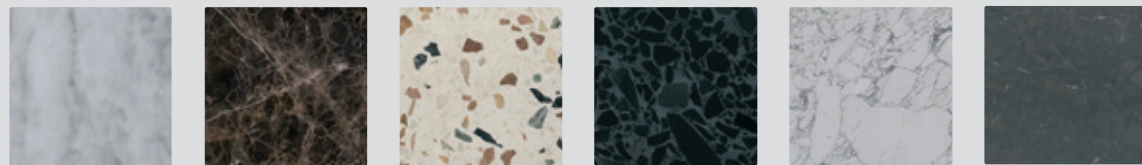

Carrara    Emperador    Murano    Burano    Arabescato    Breccia Imperiale



Fabric Remix / 123    Fabric Remix / 163    Fabric Remix / 223    Fabric Remix / 242    Fabric Remix / 433    Fabric Remix / 773



Fabric Remix / 823    Fabric Remix / 852    Fabric Remix / 933    Fabric Remix / 982    Fabric Ponza 7027.13    Fabric Ponza 7027.25

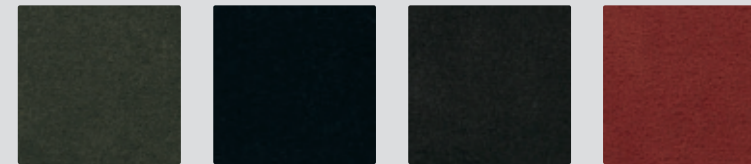

Fabric Ponza 7027.31    Fabric Ponza 7027.29    Fabric Ponza 7027.14    Fabric Ponza 7027.02

leather



Leather Vision / Polvere    Leather Vision / Cognac    Leather Vision / Terracotta    Leather Vision / Granada    Leather Vision / Amarena    Leather Vision / Constagna

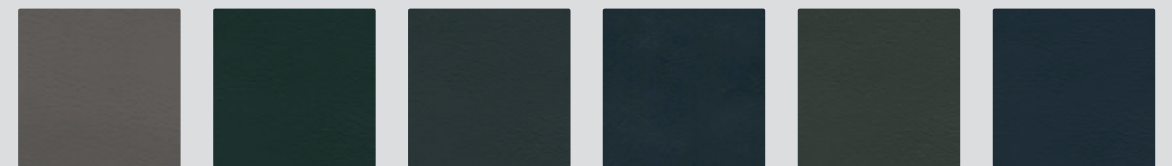

Leather Vision / Visione    Leather Vision / Foresta    Leather Vision / Piombo    Leather Vision / Nero    Leather Thema 6291    Leather Thema 6293

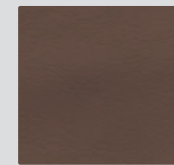

Leather Vision / Cammello

**Woak**

**23**