

Isola

M - 600

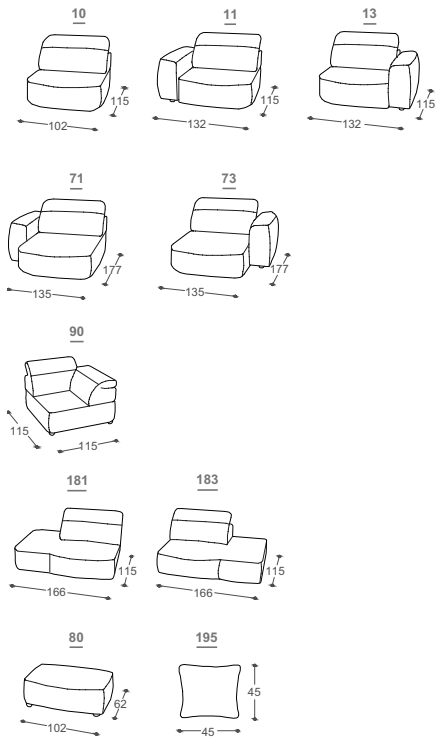

Height | 75/98
 Seat height | 42
 Seat depth | 61

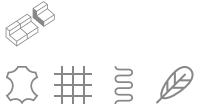

Description of used raw materials:

Wooden frame Supporting structure made of dried beech wood, 16 mm thick chipboard, cardboard, 18 mm thick plywood, 3 mm thick hardboard.

Seating Combined hard foam and high-elasticity HR foam, cushions filled with feathers, 300 g of thermal bonded cotton batting, coil springs.

Backrest Ergonomic high-elasticity foam, cushions filled with feathers, rubber bands, adjustable headrest.

Legs Legs made of beech wood, stained and varnished. Available in six colours. Chrome legs are an option.

Feature Fixed corner sofa.

Textiles In addition to having multiple choices when it comes to the sofa's components, you can also choose the covering from our wide range of imported fabrics and hides