

Layer

M - 504

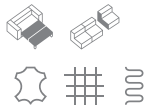

Height | 93
 Seat height | 47
 Seat depth | 56



*Lattoflex Bett

Sleeping area
 251, 252, 253
 > 140 x 198 x 12 cm
 232
 > 140 x 198 x 18 cm
 351, 352, 353
 > 160 x 198 x 12 cm

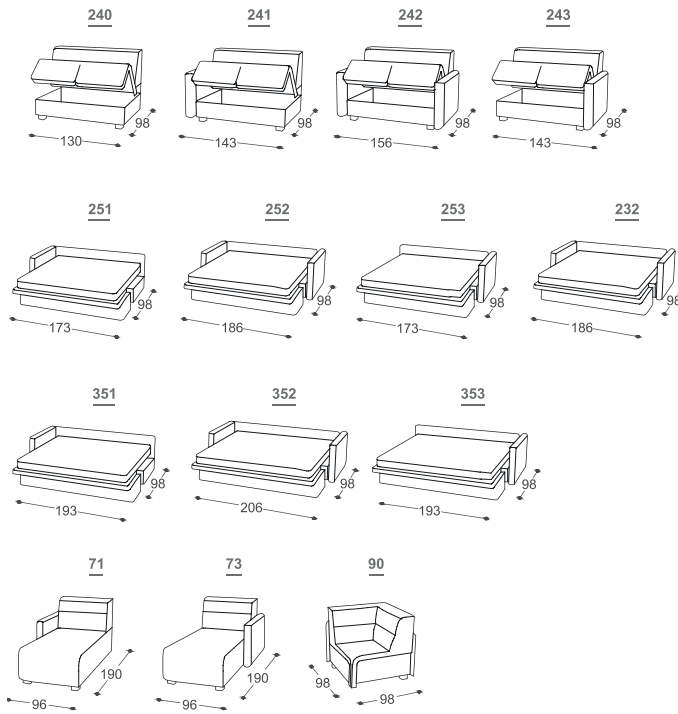

Description of used raw materials:

Wooden frame Supporting structure made of dried beech wood, 16 mm thick chipboard, cardboard, 18 mm thick plywood, 3 mm thick hardboard.

Seating High-elasticity HR foam, 300 g of thermal bonded cotton batting, coil.

Backrest Ergonomic high-elasticity foam, rubber bands.

Legs Legs made of beech wood, stained and varnished. Available in six colours.

Feature Pull-out bed is an option for two-seat and three-seat sofas.

Textiles In addition to having multiple choices when it comes to the sofa's components, you can also choose the covering from our wide range of imported fabrics and hides.